



Cobramatic® Wire Feed Cabinet Owner's Manual

Product:	Cobramatic®
Manual:	091-0539
Serial:	06110001
Voltage Rating:	115 VAC
Revision:	January 2010 Rev E
Model Number:	150-006



Table of Contents

Safety Guidelines

Installation	Section A
Technical Specifications.....	1
Machine Grounding.....	1
Machine Location.....	1
Input Power Connections.....	1
Wire Threading Procedure.....	2
Welding Gun Connections	3

Operation.....	Section B
General Description	4
Recommended Processes and Equipment.....	4
Controls and Settings.....	5
POSA Start Operating Procedure	6
Remote Operation.....	7

Accessories	Section C
Optional Kits.....	8

Maintenance	Section D
Routine Maintenance.....	8
Testing the Feeder	8
Testing the Gun.....	9

Troubleshooting	Section E
Troubleshooting Guide.....	10

Diagrams/Parts List	Section F
Main PC Boards.....	13
Mechanical.....	15
Electrical	22

Safety Warnings

Warranty

Declaration of Conformity for European Community (CE) Products

Note  This information is provided for units with CE certification (see rating label on unit).

Manufacturer's Name: **MK Products, Inc.**
16882 Armstrong Ave.
Irvine, CA 92606

Declares that the product: **Cobramatic®**
conforms to the following Directives and Standards:

Directives

Low Voltage Directive: 73/23/EEC

Electromagnetic Compatibility (EMC) Directive: 89/336/EEC

Standards

Arc Welding Equipment Part I: Welding Power Sources: IEC 60974-1
(September 1998 - Second Edition)

Arc Welding Equipment: Wirefeed Systems: IEC 974-5
(September 1997 - Draft Revision)

Degrees of Protection Provided by Enclosures (IP Code): IEC 529:1989
(November 1989 - First Edition)

Insulation Coordination For Equipment With Low-Voltage Systems:
Part I: Principles, Requirements and Tests: IEC 664-1: 1992
(October 1992 - First Edition)

Electromagnetic Compatibility, (EMC): EN 50199
(August 1995)

Torches And Guns For Arc Welding, EN 50078

SAFETY CONSIDERATIONS

ELECTRIC ARC WELDING EQUIPMENT

CAUTION : READ BEFORE ATTEMPTING INSTALLATION, OPERATION OR MAINTENANCE OF THIS EQUIPMENT

1-1 INTRODUCTION

This equipment is intended for ultimate application by commercial/industrial users and for operation by persons trained and experienced in the use and maintenance of welding equipment. Operation should not be undertaken without adequate training in the use of such equipment. Training is available from many public and private schools or similar facilities.

Safe practices in the installation, operation and maintenance of this equipment requires proper training in the art, a careful study of the information provided with the equipment, and the use of common sense. Rules for safe use are generally provided by suppliers of welding power sources, compressed gas suppliers, and electrode suppliers. Careful compliance with these rules will promote safe use of this equipment.

The following Safety Rules cover some of the more generally found situations. READ THEM CAREFULLY. In case of any doubt, obtain qualified help before proceeding.

1-2 GENERAL PRECAUTIONS

A. BURN PREVENTION

ELECTRIC ARC WELDING PRODUCES HIGH INTENSITY HEAT AND ULTRAVIOLET RADIANT ENERGY WHICH MAY CAUSE SERIOUS AND PERMANENT EYE DAMAGE AND WHICH MAY DAMAGE ANY EXPOSED SKIN AREAS.

Wear helmet with safety goggles or glasses with side shields underneath, appropriate filter lenses or plates (protected by clear cover glass). This is a must for welding or cutting (and chipping) to protect the eyes from radiant energy and flying metal. Replace cover glass when broken, pitted, or spattered.

Medical first aid and eye treatment. First aid facilities and a qualified first aid person should be available for each shift unless medical facilities are close by for immediate treatment of flash burns of the eyes and skin burns.

Wear protective clothing - leather (or asbestos) gauntlet gloves, hat, and high safety-toe shoes. Button shirt collar and pocket flaps, and wear cuffless trousers to avoid entry of sparks and slag.

Avoid oily or greasy clothing. A spark may ignite them.

Flammable hair preparations should not be used by persons intending to weld or cut.

Hot metal such as electrode stubs and work pieces should never be handled without gloves.

Ear plugs should be worn when working on overhead or in a confined space. A hard hat should be worn when others work overhead.

B. TOXIC FUME PREVENTION

WARNING: The use of this product may result in exposure to chemicals known to the State of California to cause cancer and birth defects or other reproductive harm.

Adequate ventilation. Severe discomfort, illness or death can result from fumes, vapors, heat, or oxygen enrichment or depletion that welding (or cutting) may produce. Prevent them with adequate ventilation. NEVER ventilate with oxygen.

Lead-, cadmium-, zinc-, mercury-, beryllium-bearing and similar materials, when welded or cut, may produce harmful concentrations of toxic fumes. Adequate local exhaust ventilation must be used, or each person in the area, as well as the operator, must wear an air-supplied respirator. For beryllium, both must be used.

Metals coated with or containing materials that emit toxic fumes should not be heated unless coating is removed from the work surface, the area is well ventilated, or the operator wears an air-supplied respirator.

Work in a confined space only while it is being ventilated and, if necessary, while wearing an air-supplied respirator.

Gas leaks in a confined space should be avoided. Leaked gas in large quantities can change oxygen concentration dangerously. Do not bring gas cylinders into a confined space.

Leaving confined space, shut OFF gas supply at source to prevent possible accumulation of gases in the space if downstream valves have been accidentally opened or left open. Check to be sure that the space is safe before reentering it.

Vapors from chlorinated solvents can be decomposed by the heat of the arc (or flame) to form PHOSGENE, a highly toxic gas, and other lung and eye irritating products. The ultraviolet (radiant) energy of the arc can also decompose trichloroethylene and perchloroethylene vapors to form phosgene. DO NOT WELD or cut where solvent vapors can be drawn into the welding or cutting atmosphere or where the radiant energy can penetrate to atmospheres containing even minute amounts of trichloroethylene or perchloroethylene.

C. FIRE AND EXPLOSION PREVENTION

Causes of fire and explosion are: combustibles reached by the arc, flame, flying sparks, hot slag, or heated material, misuse of compressed gases and cylinders, and short circuits.

BE AWARE THAT flying sparks or falling slag can pass through cracks, along pipes, through windows

or doors, and through wall or floor openings, out of sight of the goggled operator. Sparks can fly many feet.

To prevent fires and explosion:

Keep equipment clean and operable, free of oil, grease, and (in electrical parts) of metallic particles that can cause short circuits.

If combustibles are in area, do NOT weld or cut. Move the work if practicable, to an area free of combustibles. Avoid paint spray rooms, dip tanks, storage areas, ventilators. If the work cannot be moved, move combustibles at least 35 feet away, out of reach of sparks and heat; or protect against ignition with suitable and snug-fitting, fire-resistant covers or shields.

Walls touching combustibles on opposite sides should not be welded on (or cut). Walls, ceilings, and floor near work should be protected by heat-resistant covers or shields.

Fire watcher must be standing by with suitable fire extinguishing equipment during and for some time after welding or cutting if:

1. Appreciable combustibles (including building construction) are within 35 feet.
2. Appreciable combustibles are further than 35 feet, but can be ignited by sparks.
3. Openings (concealed or visible) in floors or walls within 35 feet may expose combustibles to sparks.
4. Combustibles adjacent to walls, ceilings, roofs, or metal partitions can be ignited by radiant or conducted heat.

Hot work permit should be obtained before operation to ensure supervisor's approval that adequate precautions have been taken.

After work is done, check that area is free of sparks, glowing embers, and flames.

An empty container that held combustibles, or that can produce flammable or toxic vapors when heated, must never be welded on or cut, unless container has first been cleaned in accordance with industry standards.

This includes: a thorough steam or caustic cleaning (or a solvent of water washing, depending on the combustible's solubility), followed by purging and inerting with nitrogen or carbon dioxide, and using protective equipment.

Water-filling just below working level may substitute for inerting.

A container with unknown contents should be cleaned (see paragraph above). Do NOT depend on sense of smell or sight to determine

if it is safe to weld or cut.

Hollow castings or containers must be vented before welding or cutting. They can explode.

Explosive atmospheres. NEVER weld or cut where the air may contain flammable dust, gas, or liquid vapors (such as gasoline).

D. COMPRESSED GAS EQUIPMENT

The safe handling of compressed gas equipment is detailed in numerous industry publications. The following general rules cover many of the most common situations.

1. Pressure Regulators

Regulator relief valve is designed to protect only the regulator from overpressure; it is not intended to protect any downstream equipment. Provide such protection with one or more relief devices.

Never connect a regulator to a cylinder containing gas other than that for which the regulator was designed.

Remove faulty regulator from service immediately for repair (first close cylinder valve). The following symptoms indicate a faulty regulator:

Leaks - if gas leaks externally.

Excessive Creep - if delivery pressure continues to rise with downstream valve closed.

Faulty Gauge - if gauge pointer does not move off stop pin when pressurized, nor returns to stop pin after pressure release.

Repair. Do NOT attempt repair. Send faulty regulators for repair to manufacturer's designated repair center, where special techniques and tools are used by trained personnel.

2. Cylinders

Cylinders must be handled carefully to prevent leaks and damage to their walls, valves, or safety devices:

Avoid electrical circuit contact with cylinders including third rails, electrical wires, or welding circuits. They can produce short circuit arcs that may lead to a serious accident. (See 1-3C)

ICC or DOT marking must be on each cylinder. It is an assurance of safety when the cylinder is properly handled.

Identifying gas content. Use only cylinders with name of gas marked on them; do not rely on color to identify gas content. Notify supplier if unmarked. NEVER DEFACE or alter name, number, or other markings on a cylinder. It is illegal and hazardous.

Empties: Keep valves closed, replace caps securely; mark MT; keep them separate from FULLS, and return promptly.

Prohibited use. Never use a cylinder or its contents for other than its intended use, NEVER as a support or roller.

Locate or secure cylinders so they cannot be knocked over.

Passageways and work areas. Keep cylinders clear of areas where they may be stuck.

Transporting cylinders. With a crane, use a secure support such as a platform or cradle. Do NOT lift cylinders off the ground by their valves or caps, or by chains, slings, or magnets.

Do NOT expose cylinders to excessive heat, sparks, slag, and flame, etc. that may cause rupture. Do not allow contents to exceed 55 degrees C (130 degrees F.) Cool with water spray where such exposure exists.

Protect cylinders, particularly valves from bumps, falls, falling objects, and weather. Replace caps securely when moving cylinders.

Stuck valve. Do NOT use a hammer or wrench to open a cylinder valve that cannot be opened by hand. Notify your supplier.

Mixing gases. NEVER try to mix any gases in a cylinder.

NEVER refill any cylinder.

Cylinder fittings should never be modified or exchanged.

3. Hose

Prohibited use. Never use hose other than that designed for the specified gas. A general hose identification rule is: red for fuel gas, green for oxygen, and black for inert gases.

Use ferrules or clamps designed for the hose (not ordinary wire or other substitute) as a binding to connect hoses to fittings.

No copper tubing splices. Use only standard brass fittings to splice hose.

Avoid long runs to prevent kinks and abuse. Suspend hose off ground to keep it from being run over, stepped on, or otherwise damaged.

Coil excess hose to prevent kinks and tangles.

Protect hose from damage by sharp edges, and by sparks, slag, and open flame.

Examine hose regularly for leaks, wear, and loose connections. Immerse pressured hose in water; bubbles indicate leaks

Repair leaky or worn hose by cutting area out and splicing. Do NOT use tape.

4. Proper Connections

Clean cylinder valve outlet of impurities that may clog orifices and damage seats before connecting regulator. Except for hydrogen, crack valve momentarily, pointing outlet away from people and sources of ignition. Wipe with a clean, lintless cloth.

Match regulator to cylinder. Before connecting, check that the regulator label and cylinder marking agree, and that the regulator inlet and cylinder outlet match. NEVER Connect a regulator designed for a particular gas or gases to a cylinder containing any other gas.

Tighten connections. When assembling threaded connections, clean and smooth seats where necessary. Tighten. If connection leaks, disassemble, clean, and retighten, using properly fitting wrench.

Adapters. Use a CGA adapter (available from your supplier) between cylinder and regulator, if one is required. Use two wrenches to tighten adapter marked RIGHT and LEFT HAND threads.

Regulator outlet (or hose) connections may be identified by right hand threads for oxygen and left hand threads (with grooved hex on nut or shank) for fuel gas.

5. Pressurizing Steps:

Drain regulator of residual gas through suitable vent before opening cylinder (or manifold valve) by turning adjusting screw in (clockwise). Draining prevents excessive compression heat at high pressure seat by allowing seat to open on pressurization. Leave adjusting screw engaged slightly on single-stage regulators.

Stand to side of regulator while opening cylinder valve.

Open cylinder valve slowly so that regulator pressure increases slowly. When gauge is pressurized (gauge reaches regulator maximum) leave cylinder valve in following position: for oxygen and inert gases, open fully to seal stem against possible leak; for fuel gas, open to less than one turn to permit quick emergency shut-off.

Use pressure charts (available from your supplier) for safe and efficient recommended pressure settings on regulators.

Check for leaks on first pressurization and regularly thereafter. Brush with soap solution. Bubbles indicate leaks. Clean off soapy water after test; dried soap is combustible.

E. USER RESPONSIBILITIES

Follow all Safety Rules.

Remove leaky or defective equipment from service immediately for repair. Read and follow user manual instructions.

F. LEAVING EQUIPMENT UNATTENDED

Close gas supply at source and drain gas.

G. ROPE STAGING-SUPPORT

Rope staging-support should not be used for welding or cutting operation; rope may burn.

1-3 ARC WELDING

Comply with precautions in 1-1, 1-2, and this section. Arc Welding, properly done, is a safe process, but a careless operator invites trouble. The equipment carries high currents at significant voltages. The arc is very bright and hot. Sparks fly, fumes rise, ultraviolet and infrared energy radiates, weldments are hot, and compressed gases may be used. The wise operator avoids unnecessary risks and protects himself and others from accidents.

A. BURN PROTECTION

Comply with precautions in 1-2.

The welding arc is intense and visibly bright. Its radiation can damage eyes, penetrate lightweight clothing, reflect from light-colored surfaces, and burn the skin and eyes. Skin burns resemble acute sunburn; those from gas-shielded arcs are more severe and painful.

DON'T GET BURNED; COMPLY WITH PRECAUTIONS.

1. Protective Clothing

Wear long-sleeve clothing in addition to gloves, hat, and shoes. As necessary, use additional protective clothing such as leather jacket or sleeves, flameproof apron, and fire-resistant leggings. Avoid outer garments of untreated cotton.

Bare skin protection. Wear dark, substantial clothing. Button collar to protect chest and neck, and button pockets to prevent entry of sparks.

2. Eye and Head Protection

Protect eyes from exposure to arc. Eyes may be damaged by radiant energy when exposed to the electric arc, even when not looking in the direction of the arc. Never look at an electric arc without protection.

Welding helmet or shield containing a filter plate shade no. 12 or denser must be used when welding. Place over face before striking arc.

Protect filter plate with a clear cover plate.

Cracked or broken helmet or shield should NOT be worn; radiation can be passed through to cause burns.

Cracked, broken, or loose filter plates must be replaced IMMEDIATELY. Replace clear cover plate when broken, pitted, or spattered.

Flash goggles with side shields MUST be worn under the helmet to give some protection to the eyes should the helmet not be lowered over the face before an arc is struck. Looking at an arc momentarily with unprotected eyes (particularly a high intensity gas-shielded arc) can cause a retinal burn that may leave a permanent dark area in the field of vision.

3. Protection of Nearby Personnel

Enclose the welding area. For production welding, a separate room or enclosed bay is best. In open areas, surround the operation with low-reflective, noncombustible screens or panels. Allow for free air circulation, particularly at floor level.

Viewing the weld. Provide face shields for all persons who will be looking directly at the weld.

Others working in area. See that all persons are wearing flash goggles.

Before starting to weld, make sure that screen flaps or bay doors are closed.

B. TOXIC FUME PREVENTION

Comply with precautions in 1-2B.

Generator engine exhaust must be vented to the outside air. Carbon monoxide can kill.

C. FIRE AND EXPLOSION PREVENTION

Comply with precautions in 1-2C.

Equipment's rated capacity. Do not overload arc welding equipment. It may overheat cables and cause a fire.

Loose cable connections may overheat or flash

and cause a fire.

Never strike an arc on a cylinder or other pressure vessel. It creates a brittle area that can cause a violent rupture or lead to such a rupture later under rough handling.

D. COMPRESSED GAS EQUIPMENT

Comply with precautions in 1-2D.

E. SHOCK PREVENTION

Exposed electrically hot conductors or other bare metal in the welding circuit, or in ungrounded, electrically-HOT

equipment can fatally shock a person whose body becomes a conductor. DO NOT STAND, SIT, LIE, LEAN ON, OR TOUCH a wet surface when welding without suitable protection.

To protect against shock:

Keep body and clothing dry. Never work in damp area without adequate insulation against electrical shock. Stay on a dry duckboard, or rubber mat when dampness or sweat cannot be avoided. Sweat, sea water, or moisture between body and an electrically HOT part - or grounded metal - reduces the body surface electrical resistance, enabling dangerous and possibly lethal currents to flow through the body.

1. Grounding the Equipment

When installing, connect the frames of each unit such as welding power source, control, work table, and water circulator to the building ground. Conductors must be adequate to carry ground currents safely. Equipment made electrically HOT by stray currents may shock, possibly fatally. Do NOT GROUND to electrical conduit, or to a pipe carrying ANY gas or a flammable liquid such as oil or fuel.

Three-phase connection. Check phase requirement of equipment before installing. If only three-phase power is available, connect single-phase equipment to only two wires of the three-phase line. Do NOT connect the equipment ground lead to the third (live) wire, or the equipment will become electrically HOT - a dangerous condition that can shock, possibly fatally.

Before welding, check ground for continuity. Be sure conductors are touching bare metal of equipment frames at connections.

If a line cord with a ground lead is provided with the equipment for connection to a switch box, connect the ground lead to the grounded switch box. If a three-prong plug is added for connection to a grounded mating receptacle, the ground lead must be connected to the ground prong only. If the line cord comes with a three-prong plug, connect to a grounded mating receptacle. Never remove the ground prong from a plug, or use a plug with a broken ground prong.

2. Connectors

Fully insulated lock-type connectors should be used to join welding cable lengths.

3. Cables

Frequently inspect cables for wear, cracks, and damage. IMMEDIATELY REPLACE those with excessively worn or damaged insulation to avoid possibly lethal shock from bared cable. Cables

with damaged areas may be taped to give resistance equivalent to original cable.

Keep cable dry, free of oil and grease, and protected from hot metal and sparks.

4. Terminals and Other Exposed Parts

Terminals and other exposed parts of electrical units should have insulating covers secured before operation.

5. Electrode Wire

Electrode wire becomes electrically HOT when the power switch of gas metal-arc welding equipment is ON and welding gun trigger is pressed. Keep hands and body clear of wire and other HOT parts.

6. Safety Devices

Safety devices such as interlocks and circuit breakers should not be disconnected or shunted out.

Before installation, inspection, or service of equipment, shut OFF all power, and remove line fuses (or lock or red-tag switches) to prevent accidental turning ON of power. Disconnect all cables from welding power source, and pull all 115 volts line-cord plugs.

Do not open power circuit or change polarity while welding. If, in an emergency, it must be disconnected, guard against shock burns or flash from switch arcing.

Leaving equipment unattended. Always shut OFF, and disconnect all power to equipment.

Power disconnect switch must be available near the welding power source.

Thank You

For selecting a quality product. We want you to take pride in operating this product...as much pride as we have in bringing the product to you!

Please Examine Carton and Equipment For Damage Immediately

When this equipment is shipped, title passes to the purchaser upon receipt by the carrier. Consequently, claims for material damaged in shipment must be made by the purchaser against the transportation company at the time the shipment is received.

Please record your equipment identification information below for future reference. This information can be found on your machine nameplate.

Model Name & Number _____

Code & Serial Number _____

Date of Purchase _____

Whenever you request replacements parts for, or information on this equipment always supply the information you have recorded above.

Read this Owner's Manual completely before attempting to use this equipment. Save this manual and keep it handy for quick reference. Pay particular attention to the safety instructions we have provided for your protection.

Section A

Installation

Technical Specifications

Wire Diameter Capacity030 - 1/16"

Wire Spool Capacity 12" Standard

(Insulated or Non-Insulated)

Power Input 115 VAC 50/60 Hz,
..... 150 Watts Peak (1.3 amps)

Weight 41 pounds

Shipping Weight 46 pounds

Support Equipment Required

C.V. or C.C. Power Source of Sufficient Capacity for Your Needs.

Regulated Gas Supply and Hoses.

Properly Sized Power Leads from Power Source to Wire Feeder and Ground.

Coolant Recommendations for Liquid Cooled Guns

Use Cobra Coolant (Aluminum Protection), P/N 931-0060. Cobra Coolant does not contain reactive sulphur or chlorine and does not react with copper, brass or aluminum.

The coolant flow rate should be a minimum of 15 GPH (1 qt/min) between 35 and 45psi. Contact the re-circulator manufacturer for specifications on pressure.

Machine Grounding

The Cobramatic® is grounded with the power source through the input power cable. The power source grounding terminal must be properly connected to electrical ground per the power source operating manual.

Mounting Location

The cabinet should be placed in a location where it can be protected from damage. Lead lengths and accessibility must also be considered when installing the cabinet.

Input Connections

(See Cabinet and Gun Hook-Up in the Appendix)

115 VAC

Your Wire Feeder comes factory ready with a standard 3-prong plug ready to connect into any standard 115 VAC, 15 A receptacle. Several optional, pre-wired harnesses are available for different power supplies and may be factory installed for a nominal installation fee. See part numbers and description of each in the OPTIONAL KITS section of this manual.

The **115 VAC** input power is connected to the PC Board on terminal strip **J5 #1** (neutral-white) and **J5 #2** (hot-black) and Ground (green) to the Cabinet chassis. See diagram in the appendix.

Shielding Gas

In accordance with the required support equipment, the customer must provide a cylinder of shielding gas, a pressure regulator, a flow control valve, and a hose from the flow control valve to the left bottom-most fitting on the power block.

The end of the hose must have a male connector to fit the female 5/8-18 brass fitting. Use a 11/16" wrench to tighten.

Coolant Supply and Return for Liquid Cooled Guns

Using a recirculator with properly mixed coolant, as previously described, connect the coolant RETURN hose to the left middle fitting on the power block. Connect the coolant SUPPLY hose to the left top-most fitting on the power block (See Cabinet and Gun Connections page 16).

The coolant hoses must have a male 5/8-18 left-hand thread to connect to the power block fittings. Use an 11/16" wrench to tighten.

Welding Power

The electrode cable coming from the welding power supply should be affixed with a 1/2" copper ring lug. Use a 9/16" wrench to tighten.

Cable from power supply **MUST** connect to bottom bolt of power block.

Reference Input Connections figure in the Appendix.

Wire Threading Procedure

Wire Spool Installation

Release latches, and open right side door of cabinet (Reference Cobramatic® Assembly drawing).

Remove spool retainer nut from spindle hub (Reference Cobramatic® Spindle Brake Assembly drawing).

Raise wire retainer bar to latched position (Reference Cobramatic® Assembly drawing).

Install wire spool onto spindle so that wire feeds from bottom of spool towards slave motor. Make sure that the hole in the wire spool aligns with pin on spindle. The white dot on the end of the spindle will aid in this alignment.

Replace the spool retainer nut.

Lower the wire retainer bar onto the spool.

Wire Spool Drag Setting

NOTE:

Standard factory setting of the Spindle Tension Knob is set for All Other Wires.

There are two visible position settings for this Knob, IN - All Other Wires (Fig. 1) and, OUT - .030/.035 AL Only (Fig. 2). The Spindle Tension Knob must be set to match the Wire Size Selector Switch on the Cobramatic® front panel.

To change this setting, it is easily done without the spool of wire on the spindle. Remove the wire spool retainer nut and re-install it reversed back onto the Spindle Tension Knob (Fig. 3). In the "Tool Mode", the square shaped end of the retainer fits onto the Knob. Grab the retainer nut and turn in the COUNTER-CLOCKWISE direction until it stops. The Knob is now set to the OUT position (.030/.035 AL Only).

To reset the Knob back to the factory setting of All Other Wires, use the retainer nut as described above, and turn in the CLOCKWISE direction until it stops. The Spindle Knob is now set to the IN position. Turning the retainer nut and Spindle Knob in this direction may require more effort, since turning CLOCKWISE is working against a spring.

Load wire spool onto spindle according to the previous instructions.

Replace the spool retainer nut.

Lower the wire retainer bar onto the spool.



IN - All other wires
Figure 1



OUT - .030/.035
Aluminum ONLY
Figure 2



Wire Spool Retainer In "Tool
Mode"; used to change
spindle drag.
Figure 3

Wire Threading Procedure

Place wire size selector switch on front panel to the correct position for the wire being used.

Loosen end of wire from spool and cut off any kinked or bent portions.

Unreel and straighten out first 6" to 8" of wire.

Raise wire type lever on the slave motor assembly of feeder to center position.

Route wire into inlet guide, along drive roll groove, and into wire conduit.

Flip wire type lever to display name of wire type being used.

Proper tension is achieved when wire does not slip if a small amount of pressure is added to the wire between thumb and forefinger as wire exits the tip. Adjust gun idler arm tension screw as necessary.

Wire Retainer Bar

The design of the patented Cobramatic® Wire Retainer Bar performs two very important and very basic functions of the wire feeder: a) spool drag tension, and b) wire maintenance on the spool.

The spool drag tension is set by lowering the wire retainer bar onto the wire inside of the spool. The spring tension of the wire retainer bar applies enough pressure on the spool so that when the gun trigger is released, engaging the brake pall, the spool does not overrun kicking wire off the spool.

Wire maintenance on the spool is performed by the applied pressure of the surface of the wire retainer bar spread across the coiled wire on the spool. The replaceable pad of the wire retainer bar is designed to hold the wire on the spool, maintaining the smooth layering of the wire and keeping it from jumping off, and possibly electrically shorting to the cabinet chassis.

Welding Gun Connections

Control Cable

The 7-Pin "W" Clocked connector screws onto the mating receptacle on the front panel of the wire feeder. This provides all electrical signals (motor voltage, potentiometer control & trigger) to and from the feeder to the gun.

Wire Conduit Inlet

Front panel access to attach conduit to front of slave motor assembly.

Power Cable Inlet

Front panel access to attach power cable (air or water) to top of power block. Guns with ring lugs, MUST connect to top bolt of power block.

Gas Inlet

Front panel access to attach gas hose to bottom fitting of power block.

Section B

Coolant Inlet (For Liquid Cooled Guns)

Front panel access to connect the coolant hose to the middle fitting on the power block.

Work Cable (Ground)

Connect a work lead of sufficient size and length between the proper output stud on the power source and the work. Be sure the connection to the work ground makes tight metal to metal electrical contact. Improper work lead connections can result in poor arc initiation, and unsatisfactory weld results.

Consult welding power supply manufacturer for proper work lead size.

Operation

General

The AC slave motor in the feeder runs at a fast, constant speed, but has very low torque. It is always trying to feed more wire than the gun motor wants, and when the gun motor gets all the wire it wants, the slave motor automatically slows, preventing a bird's nest. Because of the low torque produced by the slave motor, a combination drag and electric brake system is used to prevent wire overrun rather than relying on spindle tension alone. The spool drag tension is produced by the patented Wire Retainer Bar mechanism to keep the wire slightly taut. The 24 VDC gun "pull" motor is controlled by a solid state speed control in the cabinet and through a potentiometer located in the gun.

The normal operating sequence of the wire feeder can be viewed on the board itself via sequence LED's. When the system is triggered, the green Trigger LED (L3) and the yellow Gas Solenoid LED (L1) illuminate simultaneously. The red Contactor/Wire Feed LED (L2) illuminates after the prepurge time. The blue Arc On LED (L4) illuminates as the arc is established. When the trigger is released the normal LED operating sequence is blue, green and red (L4, L3, & L2) turn off simultaneously followed by the yellow (L1) after the postpurge time has elapsed (Figure 4).

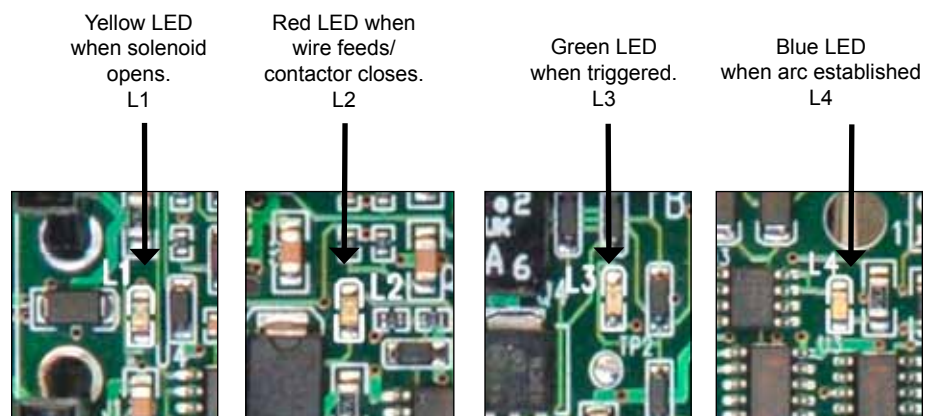

Figure 4 - L1, L2 & L3

For reference, see Main P.C. Board Connections picture in Section F

Recommended Processes and Equipment

The Cobramatic® feeder is recommended for use with GMAW and FCAW welding applications. It is recommended for use with constant voltage power sources but will also work with CC machines. The Cobramatic® feeder is capable of feeding wires (diameter capacity) ranging from .030" through .045" solid/cored and .030" through 1/16" aluminum.

Controls and Settings

On/Off Switch

Placing the switch in the "ON" position energizes the feeder circuitry and the power indicator light.

Wire Size Selector Switch

The wire size selector switch changes the torque of the slave motor for the wire you are using. When in the **.030-.035** aluminum only position, the slave motor produces approximately **1 1/2 lbs./inch** of torque and approximately **4 1/2 lbs./inch** when in the all other wires position.

NOTE:

Operating the cabinet with the switch in the wrong position will cause wire feed difficulties.

PosaStart Switch & Run In Speed Setting

The Posa Start Run-in Speed Control, located on the front panel, provides wire speed adjustment for slow wire run-in. This setting tracks as a percentage of the welding wire speed setting. Once the arc has been established, the wire feed speed automatically changes from the slow run-in speed to the welding wire speed set on the gun potentiometer.

PosaStart operation and configuration is explained later in this section.

Trigger Normal/Trigger Latched

This switch configures the electronic Trigger Latching mechanism. In the Trigger "Normal" mode, pull and hold the trigger to start welding functions - release trigger to stop welding functions. In the Trigger "Latched" mode pull and release trigger, to start welding functions- pull trigger again and release, to stop welding functions.

The Prepurge/Postpurge functions are pre-configured to provide a preset amount of pre & postpurge gas time; **0.25** and **2.0** second respectively. The default factory position of this jumper is horizontal (top right) across pins.

Changing the position of the JP3 jumper changes the configuration of the pre & postpurge sequences. Refer to Figure 5 for the desired pre and postpurge sequence. Once the desired sequence is selected, relocate on JP3 jumper from its horizontal default pattern (top right) to its new vertical sequence position.

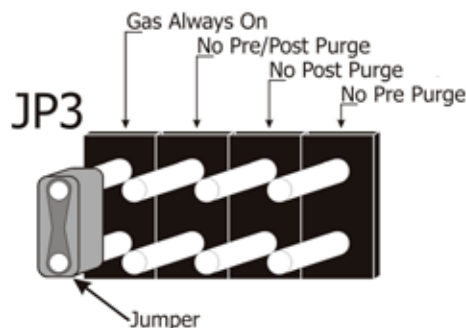

Figure 5

Pre-Purge Settings & Adjustments (JP2)

The Pre-Purge Jumper/Pot Configuration at JP2 has 3 available settings: 0.25 sec. fixed, variable from 0-1 sec. or variable from 0-5 seconds.

By default, the twin two-pin jumpers, across rows 1 & 3, are configured for 0.25 sec. Just to the left of the jumpers is a 3/4-turn potentiometer (pot) which is used with both variable settings. For the 0-1 sec. range, move the jumpers

across rows 3 & 5. For the 0-5 second range, move the jumpers across rows 5 & 7 (Figure 6a).

Timing adjustment for the variable settings are as follows: Move the jumpers to either variable setting location. Turn potentiometer screw (Small flat or cross-head) half way. Pull gun trigger and count time between red contactor wire feed LED (L2) and yellow Gas Solenoid LED (L1). Adjust pot screw as necessary.

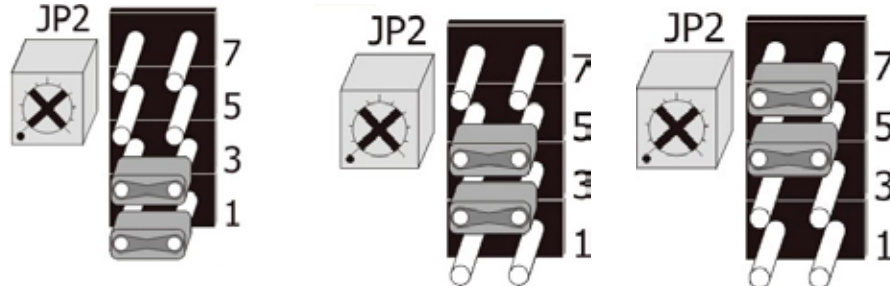

Rows 1 & 3: 0.25 sec. fixed Rows 3 & 5: 0-1 sec. Rows 5 & 7: 0-5 sec.

Figure 6a

Post-Purge Settings & Adjustments (JP1)

The Post-Purge Jumper/Pot Configuration at JP1 has 2 available settings: 2 sec. fixed and variable from 0-5 seconds.

By default, the two-pin jumper across the top-and-middle pins, is configured for 2 sec. Just to the left of the jumper is a $\frac{3}{4}$ -turn pot which is used with the variable setting. For the 0-5 second range, move the jumper from the top-and-middle to the middle-and-bottom pins (Figure 6b).

Timing adjustment for the variable settings are as follows: Move the jumpers to variable setting location. Turn potentiometer screw (Small flat or cross-head) half way. Upon release of gun trigger, count time between yellow Gas Solenoid LED (L1) and green Trigger LED (L3). Adjust as necessary.

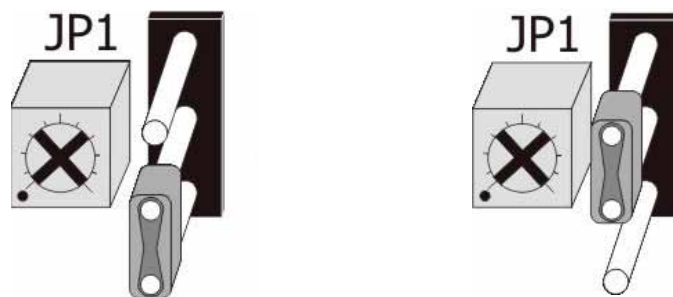

Middle/Bottom: 0-5 sec.

Top/Middle: 2 sec fixed

Figure 6b

Posa Start Operating Procedure

CAUTION:

Do not operate this wire feeder on a power source having a high-frequency (HF) starting circuit until the high frequency feature has been turned off or disabled. Failure to disable the HF will result in damage to the PosaStart circuitry of the main board.

General

The Posa Start Run-in Speed Control, located on the front panel, provides adjustment for slow wire run-in. Once the arc has been established, the wire feed speed is automatically changed from the slow run-in speed to the welding speed set on the gun potentiometer.

The Posa Start feature allows the Cobramatic® feeder and gun to be used in conjunction with constant current DC welding power sources of open circuit voltage in excess of 55 volts - also, any constant voltage welding power source capable of a minimum of 50 amps.

Once the PosaStart circuit has transferred from slow run-in to weld speed, the blue LED (L4) illuminates (Figure 7).

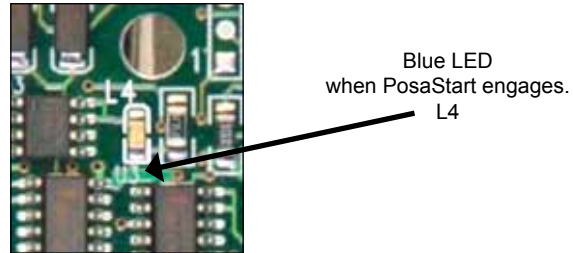

Figure 7

CV/CC Posa Start Operations

NOTE:

CV Posa Start does not need welding voltage sensing lead.

The default factory setting is CV mode. Attach Cobramatic® cabinet to CV power source according to the installation instructions.

Turn the Cobramatic® cabinet to the “ON” position and the Posa Start to the “OFF” position. Adjust power source to desired voltage for your weld condition. Depress gun trigger and adjust wire feed speed at gun to match voltage setting.

Turn the Posa Start switch to the “ON” position. Depress gun trigger and, using Run-in Speed Control, adjust wire feed rate to approximately 50% of welding wire speed set at gun.

Initiate an arc, and adjust wire feed speed at gun until correct condition is achieved. At the moment when welding wire speed transition occurs, L4 will illuminate.

POSA START WIRE SPEED NOTE:

Because the Posa Start Run-in Speed always remains a percentage of the actual welding wire feed rate, the Posa Start run-in speed will always slow down or speed up proportional to any adjustment you now make at the gun. Therefore, if you slow down the welding wire feed speed, you will have to increase the Run-in Speed setting.

Remote Operation: Input/Output

The terminal strip TB1 (reference Appendix pages) allows for external input signals for remote operation of the feeder as well as output signals for voltage and wire speed measurements, for a wide variety of automatic and semi-automatic applications. By making connections across specific points of TB1, such functions as the trigger and motor speed control can be controlled using an external source, such as a controller interface or a PLC (programmable logic controller).



Figure 8

Section C

Optional Kits

The following is a list of Optional Power Supply Interface Cable Kits available for the Cobramatic® Wire Feeder.

8ft Interface Cable for Miller 14-Pin, 115VAC005-0316

25ft Interface Cable for Miller 14-Pin, 115VAC005-0658

When properly connected, these interface cables will supply all the necessary signals and power needed, from most Miller welding power supplies: a Closing Contact signal and 115VAC input power.

8ft Interface Cable for Lincoln 14-Pin, 115VAC..... 005-0608

25ft Interface Cable for Lincoln 14-Pin, 115VAC..... 005-0659

When properly connected, these interface cables will supply all the necessary signals and power needed, from most Lincoln Electric welding power supplies: a Closing Contact signal and 115VAC input power.

8ft Interface Cable for Thermal Arc 19-Pin, 115VAC 005-0630

When properly connected, these interface cables will supply all the necessary signals and power needed, from most Thermal Arc welding power supplies: a Closing Contact signal and 115VAC input power.

8ft Interface Cable for ESAB 19-Pin, 115VAC 005-0705

When properly connected, these interface cables will supply all the necessary signals and power needed, from most ESAB welding power supplies: a Closing Contact signal and 115VAC input power.

Section D

Maintenance

Routine Maintenance

Your Cobramatic® system is designed to provide years of reliable service. Normal wear and component mortality may require occasional service.

The number of units in operation and the importance of minimal “down time” will determine to what extent spare parts should be stocked on hand.

If repairs do become necessary, any part can easily be replaced by qualified shop maintenance personnel.

Maintenance of the gun will normally consist of a general cleaning of the wire guide system, including tubes, drive rolls, and conduits at regular intervals.

Remove spatter build-up from inside of nozzles with a hardwood stick.

The only parts on the Cobramatic® system that are subject to normal wear are the conduit, contact tips, gas cups, front body liners, wire guides, drive and idler rolls (parts that contact the welding wire). A supply of these parts should be maintained.

Testing the Feeder

Testing the Input Power Circuits

The AC circuits are protected by fuses F1 and F2 (see page 15 for location). If these fail, especially when powering up the cabinet, remove the connectors for the components that draw on this power, J6 (Brake Solenoid), J7 (Slave Motor) and J5-3 & 4 (AC Contactor - if used) from the P.C. Board. Replace fuses and retrigger system. If fuses do not fail, isolate the problem by plugging in J4, J7, and J5-3,4 one at a time until the fuses fail.

Testing the Speed Control

NOTE:

The gun should be tested prior to testing circuitry on the main board. Gun amphenol must be connected to the Cobramatic® cabinet to perform the following tests.

To test the motor voltage circuit and measure how much voltage is being delivered to the gun motor, place a voltmeter across diode test points **TP1** & **TP2** and depress gun trigger. A reading between **0 - 30 VDC** should be observed, as the gun potentiometer is varied.

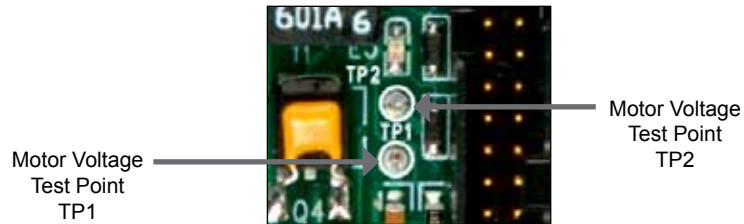

Figure 9

For reference, see Main P.C. Board Connections picture in Section F

Testing the Gun

Motor Check

Remove the amphenol connector from the cabinet.

Using the gun amphenol, check the resistance across pins "A" and "B" (motor leads). The resistance across the motor should be between **5-10 ohms**.

If an open circuit or short exists, check the motor leads and motor independently.

Testing the Potentiometer - "W" Clocked Amphenol Connector

Using the gun amphenol, check the resistance across pin "D" (wiper) and pin "C". The resistance should vary from **0 - 5K ohms** as you turn pot..

Check the resistance across pin "D" (wiper) and pin "G". The resistance should vary from **5K - 0 ohms** as you turn pot.

Testing the Micro Switch

Using the gun amphenol, check for continuity across pins "E" and "F" when the trigger is pressed.

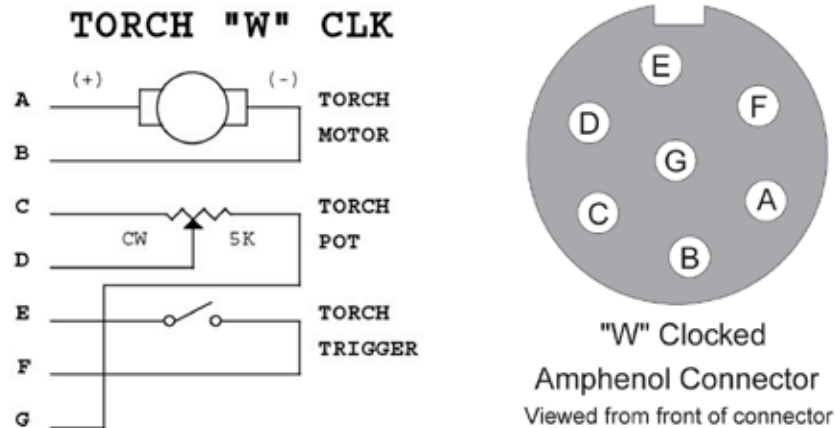

Section E Troubleshooting

Troubleshooting		
Symptom	Cause	Remedy
No wire feed at gun, feeder not operating, i.e., no slave motor or brake solenoid.	F1 & F2 fuse(s) in feeder failed.	Check AC circuit. Replace fuse(s).
	F3 (4 amp) fuse in feeder failed.	Check motor leads for shorts then replace fuse.
	Micro-switch defective/not being activated. Broken electrical cable.	Replace switch. Check switch for operation. Check micro switch wires for continuity.
	Loose J2, J3, P.C. board connector.	Check J2, J3 connectors.
Brake solenoid inoperative.	Solenoid defective.	Replace solenoid.
	Loose connector at J6.	Check J6 connector.
No wire feed at gun, feeder operating properly.	Bad potentiometer.	Check potentiometer with meter.
	Bad gun motor.	Check/Replace motor.
	Broken electrical cable.	Check motor and potentiometer wires for continuity.
	Bad speed control/PCB.	Check/Replace P.C. board.
Wire feeds, but welding wire is not energized.	Loose or no power supply cable connections.	Check all power connections.
	Contactors control cable loose or in wrong position.	Check power supply owner's manual for location and type of contactor signal required, i.e. closing contacts or AC.
	Welding power source not working correctly.	Check power supply for proper operation.
Wire feeds erratically.	Dirty or worn conduit.	Blow out or replace conduit.
	Incorrect pressure on drive rolls.	Adjust pressure at gun (Gold or Prince)
	Idler roll stuck in gun.	Check for lock washer under idler roll, or replace if damaged or worn.
	Wrong size contact tip.	See contact tip table.
Wire feeds one speed only.	Bad potentiometer.	Check with meter.
	Broken electrical cable in lead assy.	Check potentiometer wires for continuity or shorts.
	Bad speed control.	Check/Replace P.C. boards.
Wire walks out of drive rolls.	Idler roll upside-down.	Place groove in idler roll toward the top.
	Rear wire guide missing.	Replace wire guide.
Trigger inoperable or not operating correctly.	Trigger mode configuration.	Check front panel Trigger Normal/Latched toggle switch.
Purge not operating correctly.	Jumper incorrectly configured. Gas solenoid malfunctioning.	Check jumper location per Jumper Table in Appendix. Check cable connections to gas solenoid. Check valve in gun.
No PosaStart Wire Speed Transition	Welding power cable and/or gun power cable connected to wrong bolt on power block.	Welding power cable to bottom bolt. Gun power cable to top bolt.
	Welding current not being sensed.	Check current sensor in power block.
Remote Functions Not Working	Wires not connected at TB1	Reseat all wire connections at TB1.

Section F

Appendices

Diagrams/Parts List

Main P.C. Board Connections..... 13
Cabinet and Gun Connections 14
001-4021 Cobramatic® Assembly 15
003-2235 Cobramatic® Front Panel Assembly 17
003-2078 Cobramatic® Slave Motor Assembly..... 18
003-2063 Cobramatic® Power Block Assembly 19
003-2146 Cobramatic® Spindle Brake Assembly..... 20
003-2137 Gas Solenoid Assembly 21
071-0401 Cobramatic® Block Diagram 23
071-0400 Cobramatic® Main P.C. Board 22
071-0370 Cobramatic® Gun and Front Panel Connections 25
Input/Output Configuration for TB1..... 26

This page intentionally blank

Main P.C. Board Connections

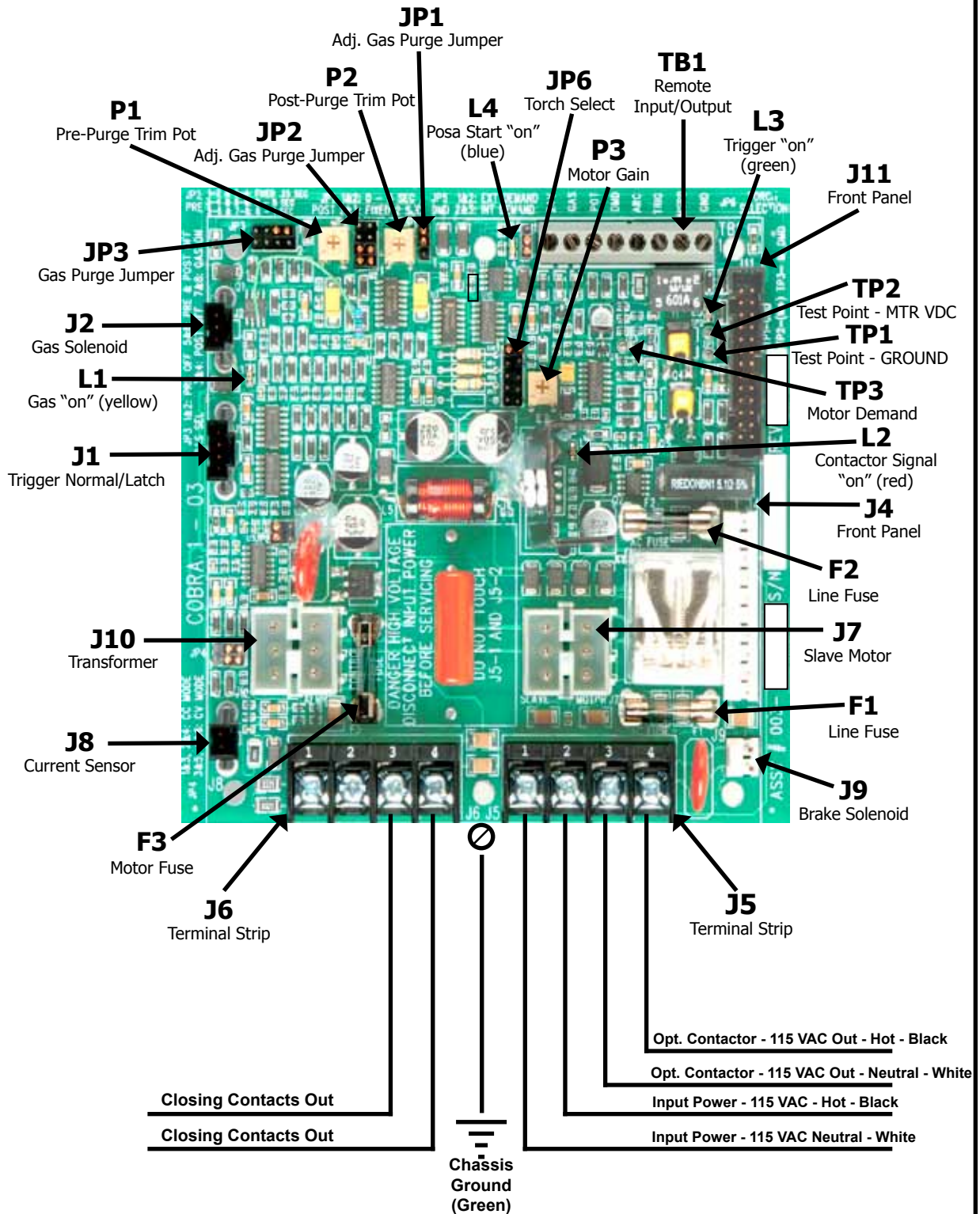

Cabinet and Gun Connections

Input Water Cooled Gun

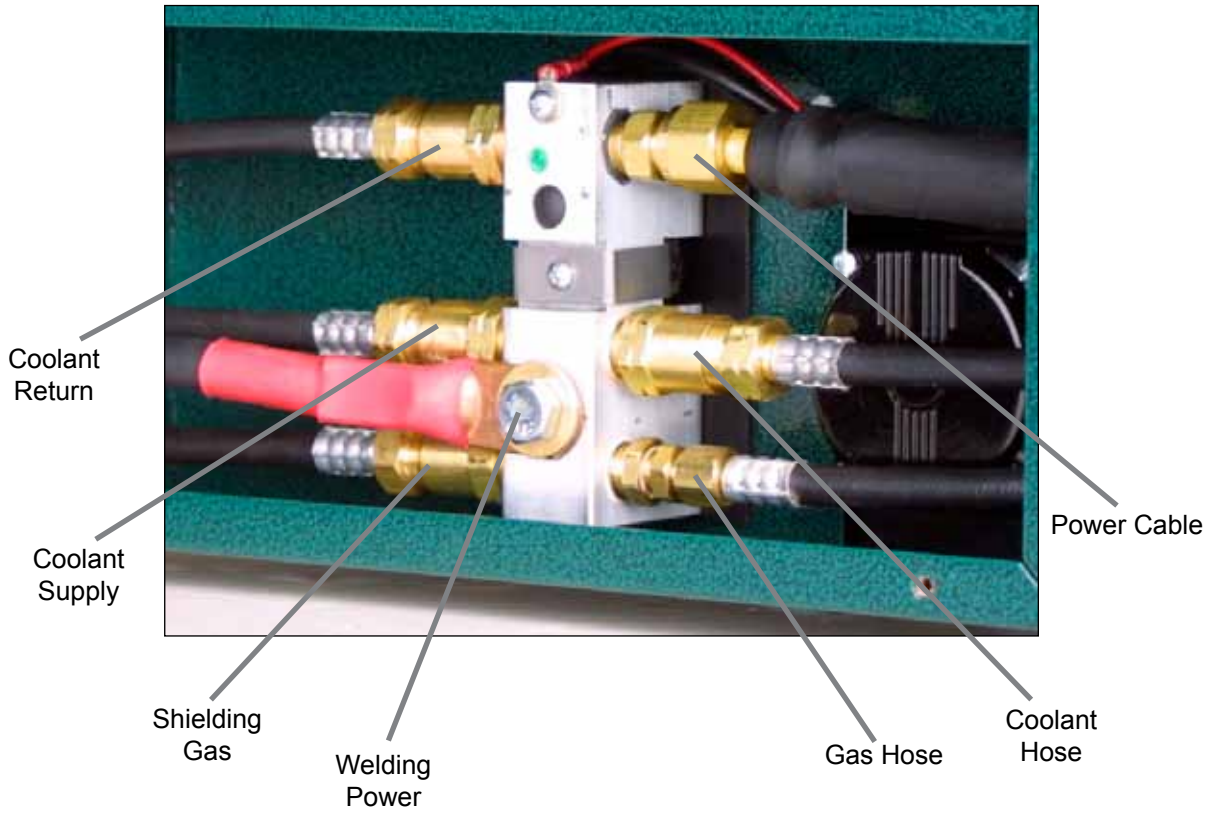

Input Air Cooled Gun

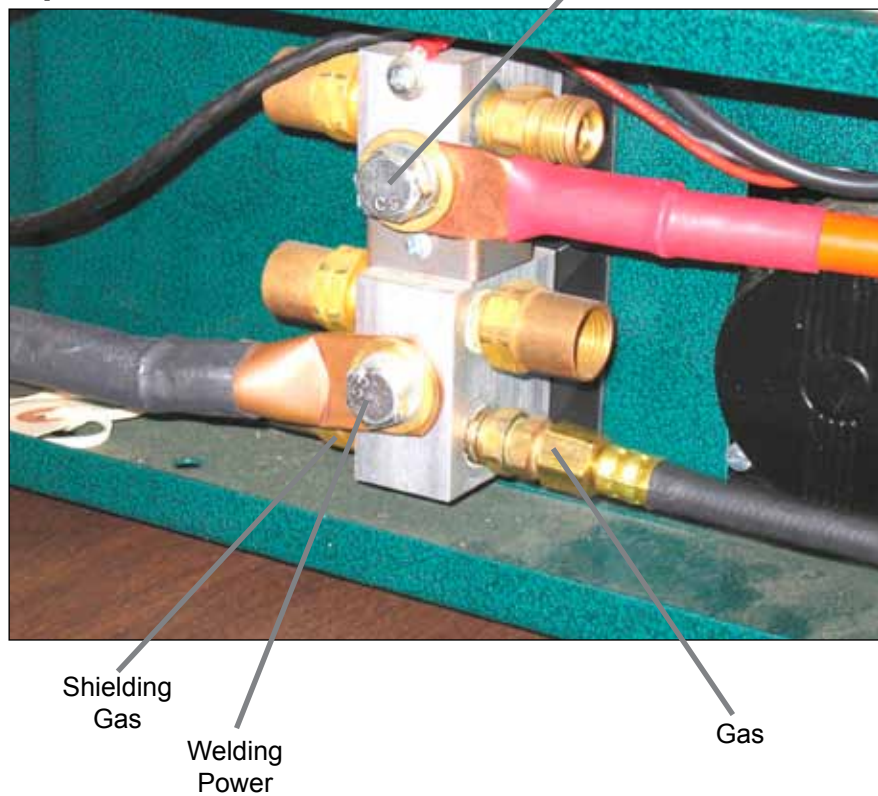

001-4021 Cobramatic Assembly

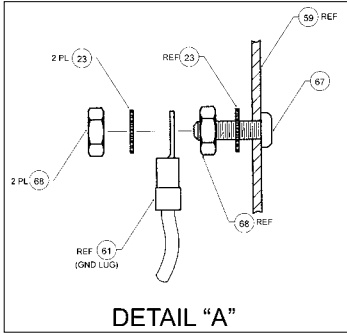
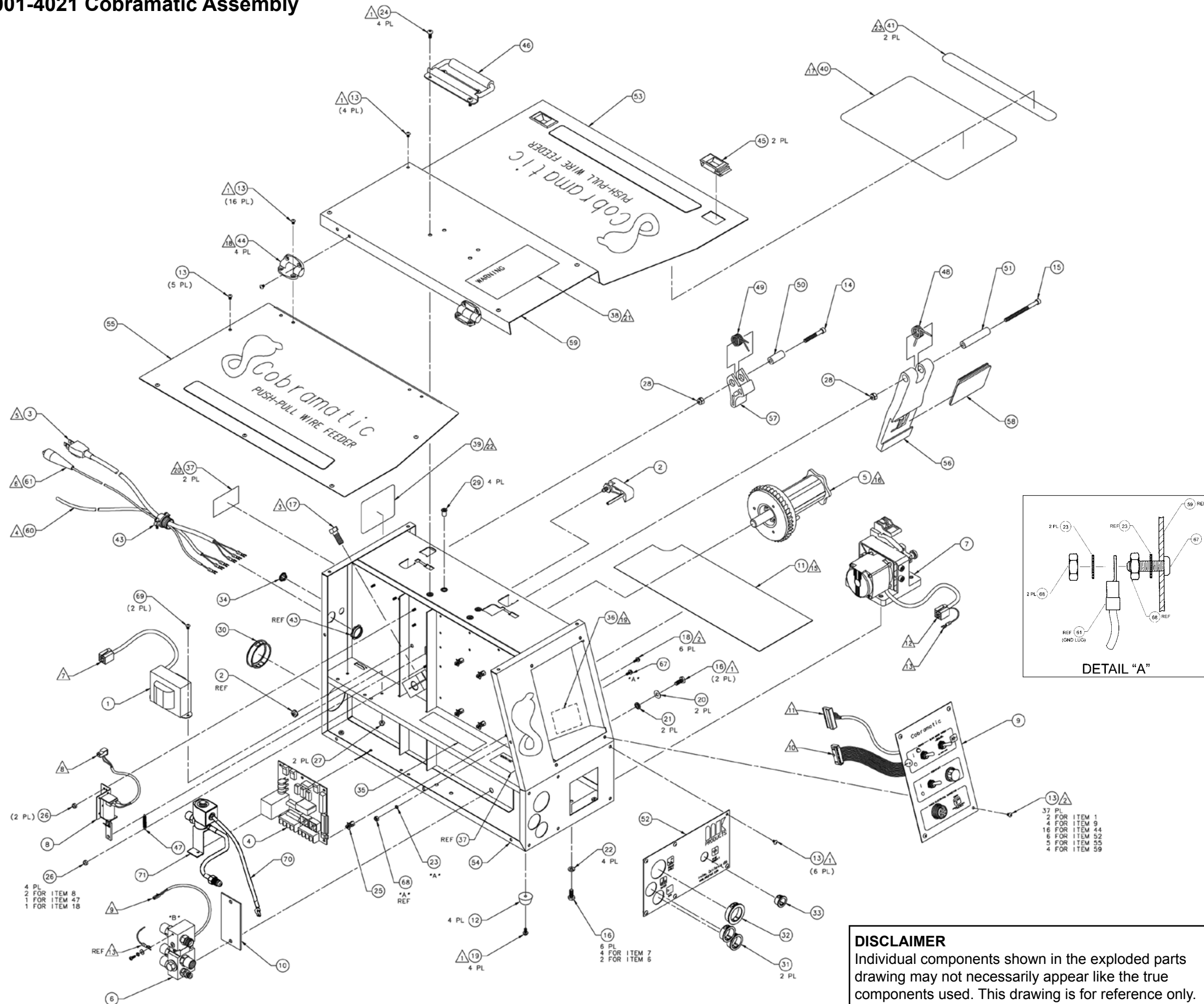

DISCLAIMER
Individual components shown in the exploded parts drawing may not necessarily appear like the true components used. This drawing is for reference only.

* NOTE: Items 72,73,74, are used with items 70 and 71

Cobramatic Assembly 001-4021			
No.	Qty.	Part No.	Description
1	1	003-0773	Assy Xfmr 115V
2	1	003-0784	Assy Pawl CB
3	1	003-0796	Cable Power
4	1	003-2111	Assy PCB Main CB I 110V
5	1	003-2146	Assy Spindle CB
6	1	003-2063	Assy Power Block
7	1	003-2078	Assy Slave Motor 115V
8	1	003-2096	Assy Sol Brk 115V Top
9	1	003-2235	Assy Pnl Fr CB
10	1	261-0635	Insulator Power Block
11	1	261-0634	Insulator Spool
12	4	301-0107	Foot Rbr W/Wshr #8 ID
13	35	336-0230	Scr Pan Phil 8-32 x 1/4 Blk
14	1	328-0063	Scr Sch 1/4-20 x 1-3/4 Blk
15	1	328-0258	Scr Sch 1/4-20 x 3 1/2 Stl
16	6	329-0002	Screw Hex 1/4-20 x 5/8
17	1	329-0208	Scr Hex 3/8-16 x 1.0
18	6	329-1007	Scr Hex Wshr Slit 6-32 x 3/8 St
19	4	329-1019	Scr Hex Wshr Slit 8-32 x 3/8 St
20	2	331-0049	Wshr Flt .261IDx.625OD
21	2	431-1650	Wshr Shldr .265IDx.365OD
22	4	333-0009	Wshr Spr LK 1/4
23	2	333-0023	Wshr LK Ext Star #6
24	4	336-0228	Scr Pnh Ph 10-32 x 1/2 Stl Blk
25	6	342-0410	Spacer Stacking 6-32 x 0.53
26	3	345-0008	Nut Hex Lock 6-32
27	2	345-0009	Nut Hex Lock 8-32 St
28	2	345-0015	Nut Hex Lock 1/4-20 St
29	4	351-0089	Insert Thread 10-32
30	1	351-0100	Bush Snap 1 5/8ID
31	2	351-0745	Bush Snap 15/16ID
32	1	351-0752	Bush Snap 1 1/8ID
33	1	351-0758	Bush Snap 9/16ID
34	1	351-0835	Snap Btn
35	1	405-0724	Decal Electronic Connection
36	1	405-0886	Decal Warning T13297
37	2	405-0887	Decal Warning T13470
38	1	405-0888	Decal Warning T6196
39	1	405-0939	Serial Number ID Plate
40	1	405-0943	Decal Instructions Door Spool
41	2	405-0944	Decal Door Caution
42	-	-	-
43	1	411-0157	Clamp Cble Str Ref
44	4	415-0075	Hinge CB
45	2	415-0079	Latch Slide
46	1	415-0243	Handle Carry Black
47	1	419-0080	Sprg Ext .219OD x .94LG
48	1	419-0089	Torsion Spring Restrainter CB
49	1	419-0090	Torsion Spring Catch
50	1	431-1608	Mandrel Catch CB
51	1	431-1609	Mandrel Restrainter Wire CB
52	1	436-0148	SS Pwr Pnl CB
53	1	436-0150	SS Door Spl CB
54	1	436-0151	SS Wrap CB
55	1	436-0152	SS Door Pwr CB
56	1	437-0242	Restrainter Wire Mold CB
57	1	437-0243	Catch Mold Restrainter CB
58	1	437-0255	Pad Restrainter Wire
59	1	438-0062	Paint Top CB
60	1	843-0064	Cable Contactor 8ft
61	1	843-0327	Cable Posastart
62	-	-	-
63	-	-	-
64	-	-	-
65	-	-	-
66	-	-	-
67	1	336-0006	Scr Pan Phil 6-32 x 1/2
68	2	341-0005	Nut Hex 6-32
69	2	336-0030	Scr Pan Phil 8-32 x 1/2 ST
70	1	003-2137	Assy Gas Solenoid
71	1	435-1464	Bracket Gas Solenoid
72*	2	333-0006	Washer Spr Lock #8
73*	2	336-0029	Scr Pn P 8-32x3/8 ST
74*	2	327-0121	Scr Pn P 10-32x3/8 ST

* Item not shown

This page intentionally blank

003-2235 Cobramatic® Front Panel Assembly

Front Panel Assy 003-2235		
No.	Qty.	Part No. Description
1	1	003-1332 Assy cbl rbn 26c
2	1	003-1631 Cable power assy
3	1	003-2024 Assy pcb fr pnl cb 1 110V
4	1	301-0023 Grommet panel mount
5	1	341-0050 Nut 3/8 - 32 st
6	2	345-0004 Nut hex lock 4-40
7	1	401-0012 Knob 1.0 blk
8	1	436-0144 SS pnl fr Cobramatic
9	1	003-1642 Assy con 7p "w" cb
10	1	003-2138 Assy swx gas/trigger

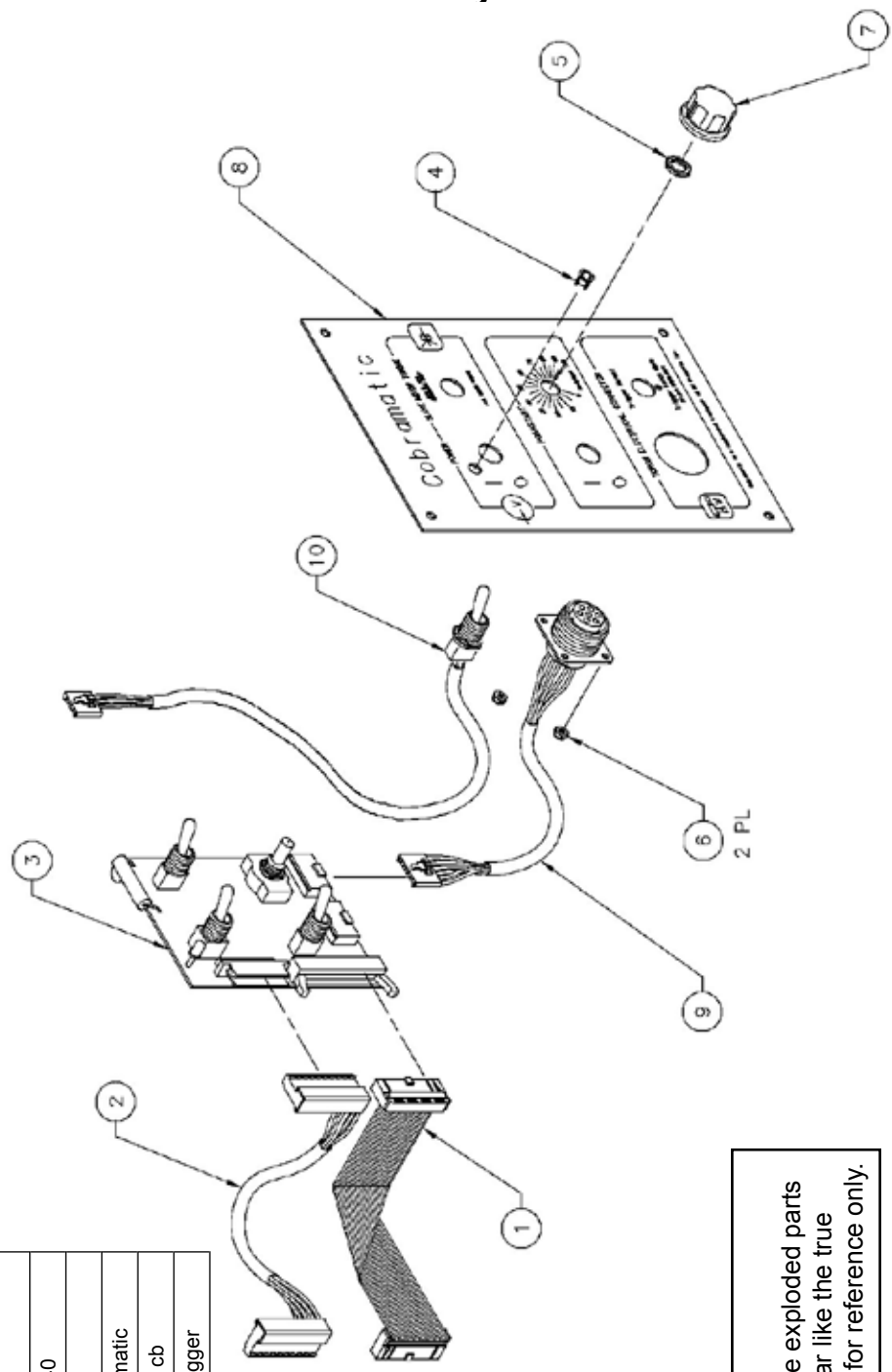

DISCLAIMER
Individual components shown in the exploded parts drawing may not necessarily appear like the true components used. This drawing is for reference only.

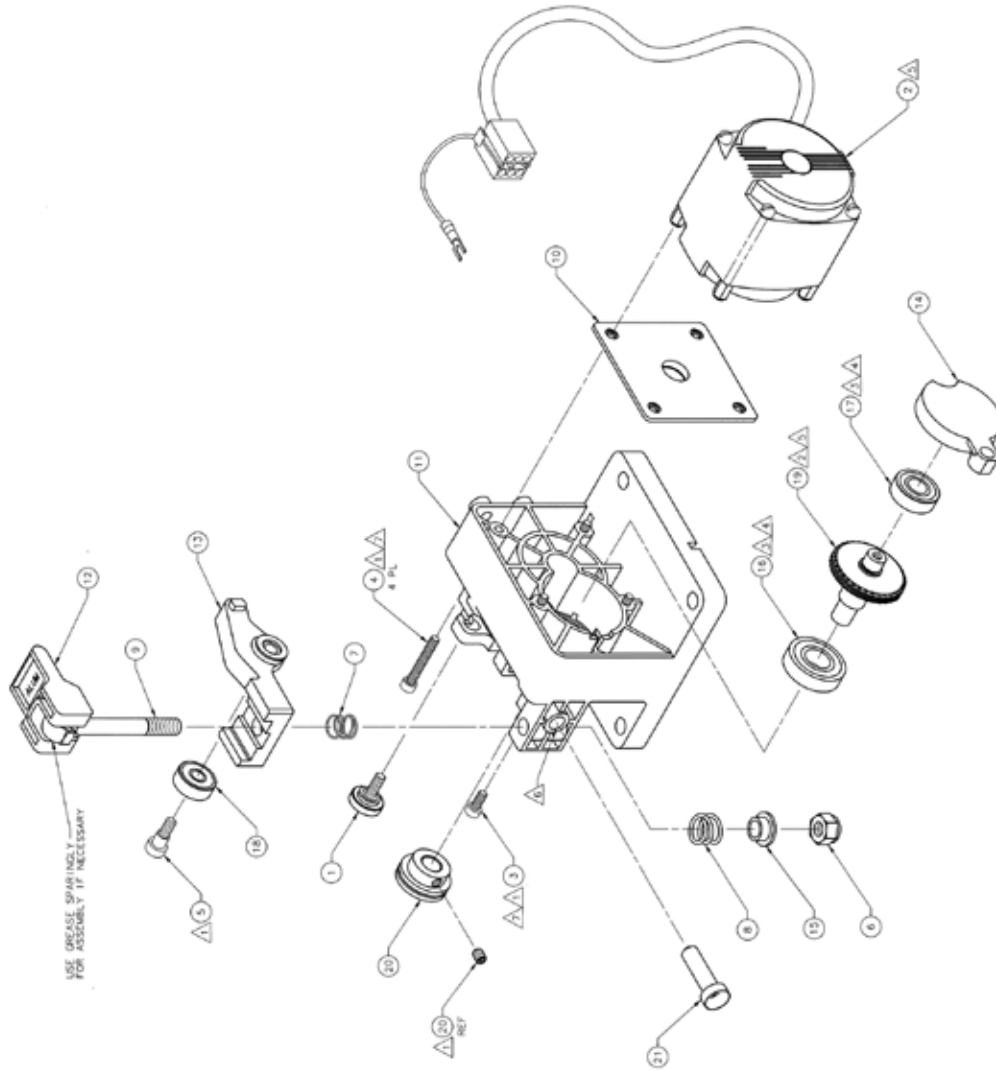

No.	Qty.	Part No.	Description
1	1	003-0176	Assy knob conduit
2	1	003-2069	Assy torque motor 115V
3	1	328-0024	Scr shc 8-32 X 3/8 stl
4	4	328-0259	Scr shc 8-32 X 1-1/8 stl
5	1	330-0258	Scr Shldr 1/4 X 1/4 X 10-24
6	1	345-0018	Nut Lock 5/16-18
7	1	419-0085	Spring comp
8	1	419-0211	Spring comp
9	1	431-1576	Bolt swing mod
10	1	435-1582	Plate locate slave motor
11	1	437-0230	Housing slave motor mold
12	1	437-0231	Handle mold slave motor
13	1	437-0232	Arm idler mold slave motor
14	1	437-0245	Cap bearing mold
15	1	437-0254	Sleeve spring
16	1	501-0118	Bearing 1.125 X .50 X .31
17	1	501-0156	Bearing, .875 X .38 X .28
18	1	501-0207	Bearing idler roll
19	1	507-0130	Shaft gear
20	1	511-0206	Drive roll
21	1	753-0210	Guide wire inlet

- ⚠ REAM, IF NEEDED, WITH #0.3130 REAMER.
- ⚠ APPLY APPROXIMATELY 10CC OF GREASE, TO GEAR TEETH.
- ⚠ APPLY RETAINING COMPOUND, SPARINGLY TO OUTSIDE DIAMETER OF BEARINGS.
- ⚠ ITEM #16 & #17 THEN INSERT INTO ITEMS #11 AND #14. USE CAUTION NOT TO GET INTO HOUSING. REMOVE ANY EXCESS ADHESIVE AFTER BEARING IS INSTALLED.
- ⚠ PRESS FIT BEARINGS (ITEMS #16 & #17) ONTO ITEM #19 WITH 100% USE-0417 (DO NOT USE LOCITITE). INSURE BEARINGS ARE PERPENDICULAR TO SHAFT.
- ⚠ CLEAN WITH SAFETY SOLVENT IN SONIC TANK PRIOR TO BEARING ASSEMBLY.
- ⚠ APPLY A MINIMAL AMOUNT REMOVABLE THREADLOCK COMPOUND TO THREADS.

003-2063

Cobramatic® Power Block Assembly

- △ Apply pipe thread sealant
- △ Apply anti-corrosive compound
- A Torque: 140 in-lb to 150 in-lb
- B Torque: 92 in-lb to 108 in-lb

Power Block Assy 003-2063

No.	Qty.	Part No.	Description
1	1	003-1243	Assy sensor Posa-Start
2	1	313-0021	Stud receiver push-on
3	2	329-0054	Scr hex 3/8-16 X 5/8
4	1	331-0002	Washer flat #6 st.
5	2	331-0777	Washer flat 0.391 ID X 0.875OD
6	1	333-0252	Wshr lk star-in #6 st.
7	2	336-0005	Scr pn ph 6-32 x .375 stl
8	1	342-0395	Spacer current sensor
9	-	-	-
10	1	431-1612	Block power cb2k
11	1	435-3038	Bracket current sensor
12	1	753-0112	Fig 1/4npt male to 5/8-18 male
13	1	753-0114	Aprtr 1/8nt X 1/8nps
14	1	753-0115	Bush 1/4npt male to 1/8mpt fem
15	1	753-0466	Aprtr 1/4npt male to 5/8-18 fem
16	3	753-0475	Aprtr 1/4npt m to 5/8-18 fem lh
17	-	-	-
18	-	-	-
19	-	-	-
20	2	333-0011	Washer Spring Lock 3/8

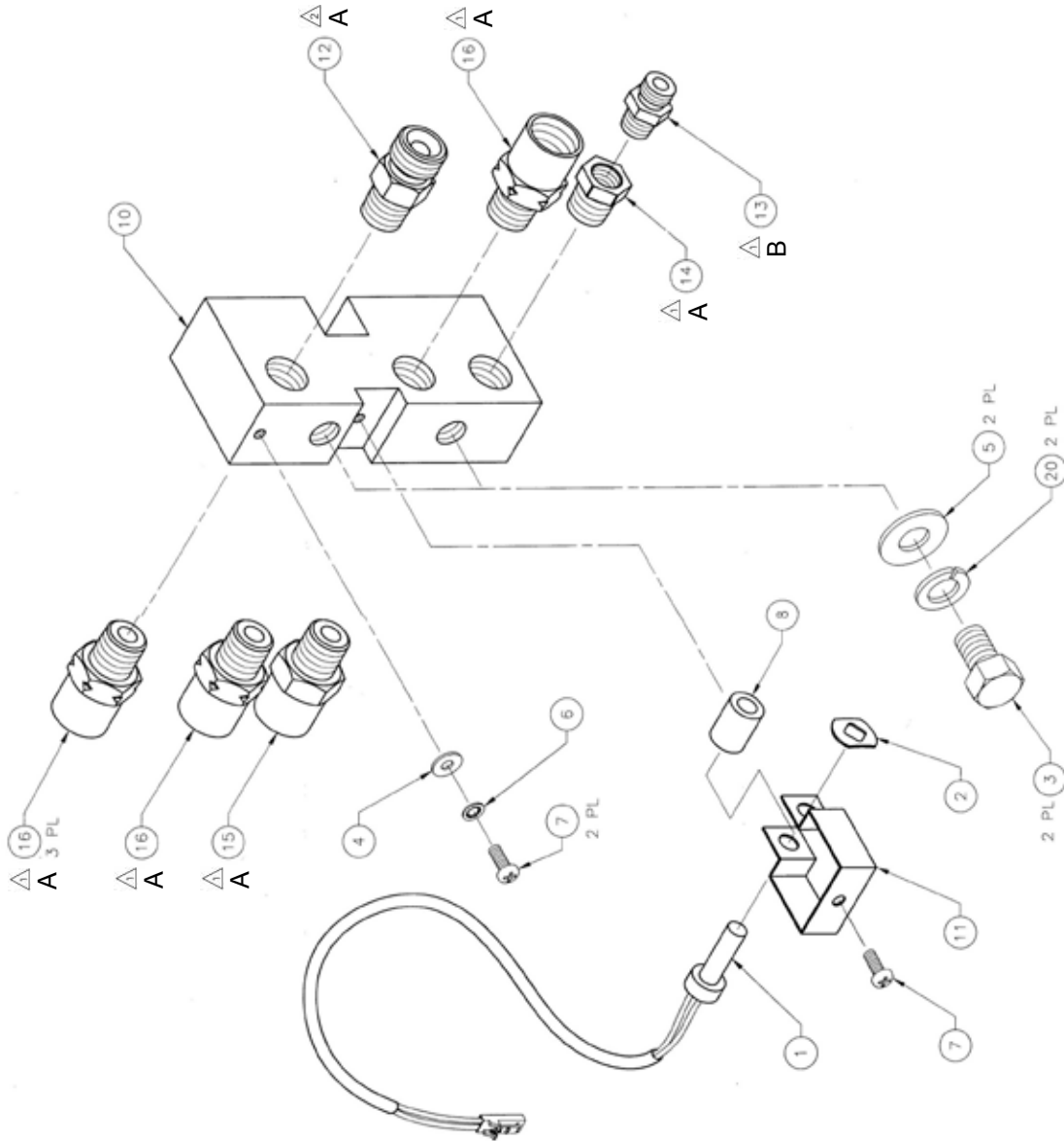

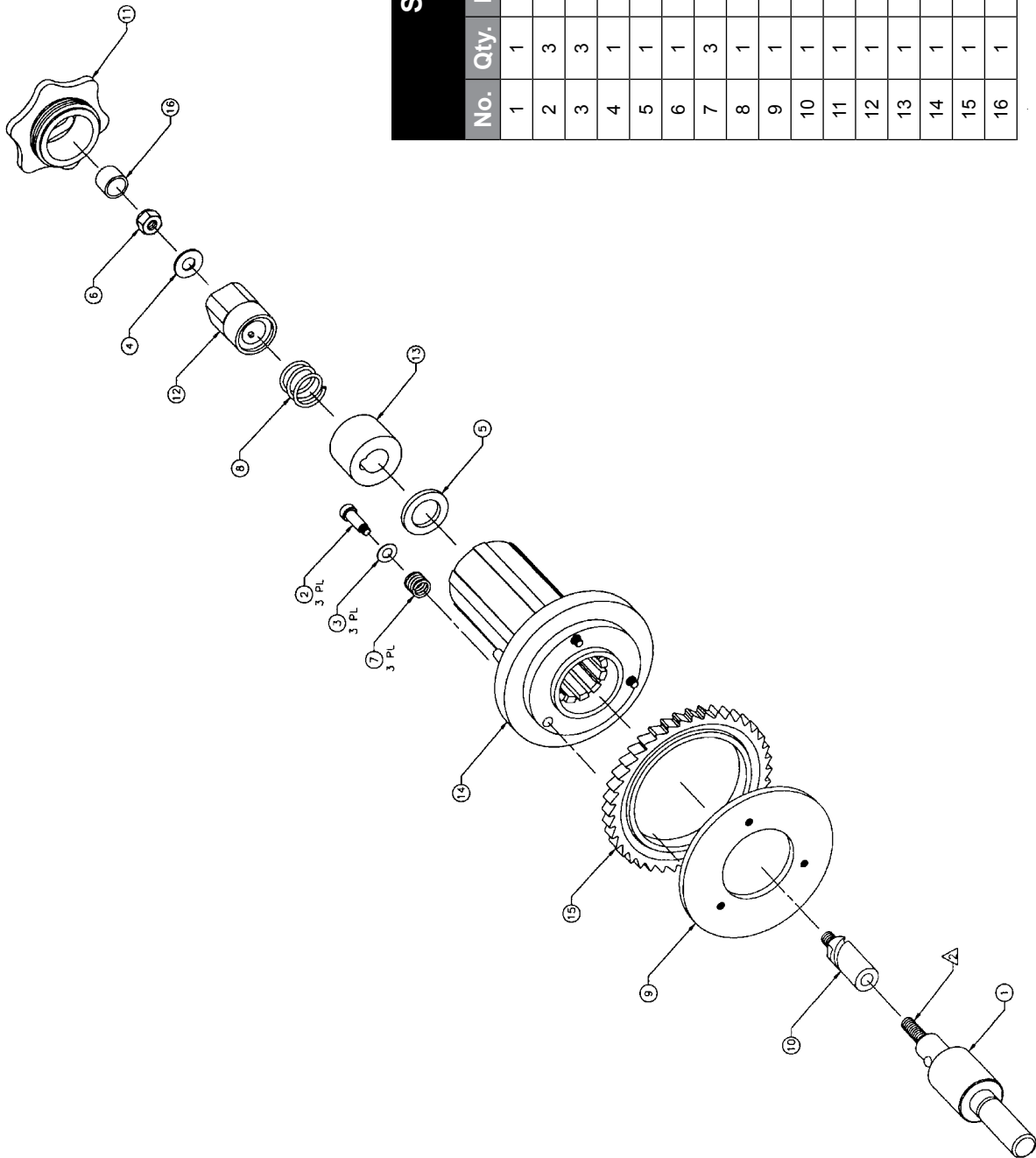

Spindle Brake Assy 003-2146		
No.	Qty.	Part No. Description
1	1	003-2139 Ass'y bearing spindle
2	3	330-3063 Scr shldr .25 X .63 10-14
3	3	331-0063 Wshr fit .355 X .505
4	1	331-0095 Wshr fit 11/32 X 3/4 sst
5	1	331-0313 Wshr leather .75 ID X .125 thk
6	1	345-0018 Nut hex lock 5/16-18 st
7	3	419-0059 spg comp .468 X .437 X .056
8	1	419-0095 Spg comp .85 X .69 X .75
9	1	431-1266 Plate back-up ring
10	1	431-3726 Adapter spiral spindle
11	1	437-0258 Spool Retainer Nut
12	1	437-0259 Knob tension spindle
13	1	437-0260 Spacer spindle
14	1	437-0645 Spindle
15	1	723-0059 Disk ratchet brake
16	1	751-0018 Cap .5 X .5 lg vinyl black

003-2137

Gas Solenoid Assembly

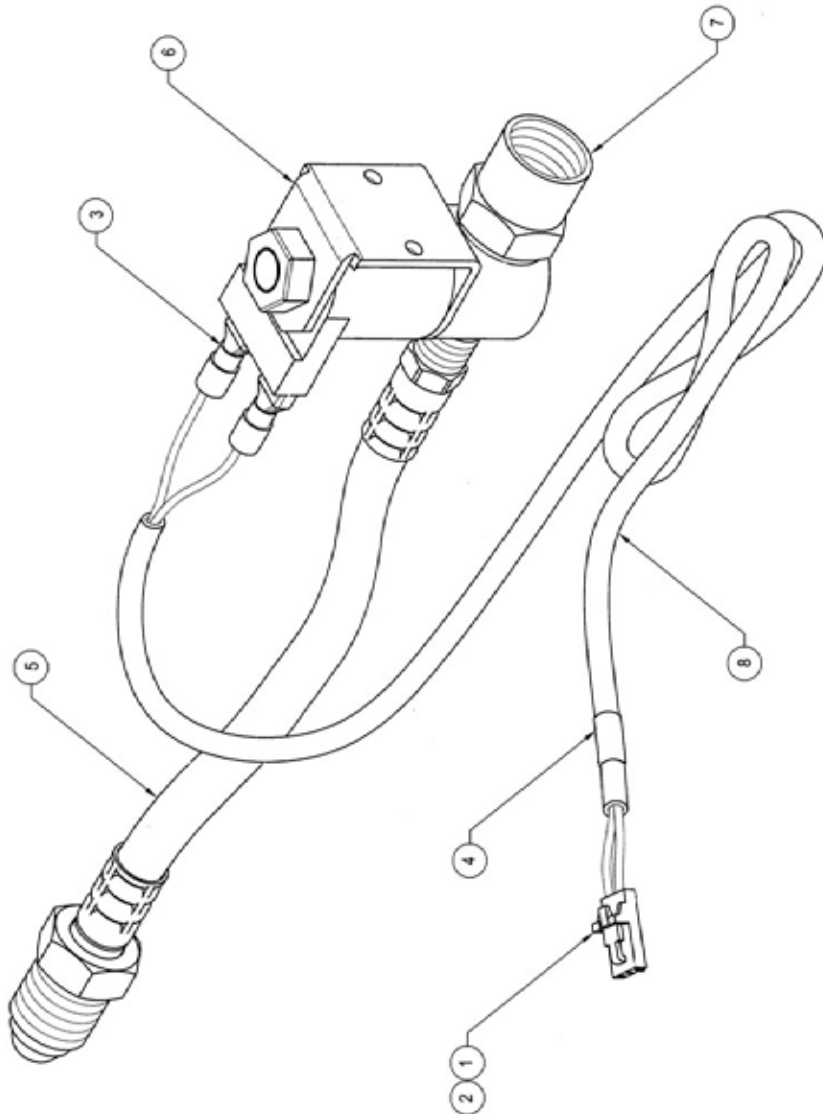

Gas Solenoid Assy 003-2137

No.	Qty.	Part No.	Description
1	2	153-0853	Pin Crimp
2	1	153-0868	Conn single row 3P
3	2	185-0476	Term slip-on female
4	1	405-0762	Label self-lam .8 x 1.4
5	1	552-0205	Assy gas connector
6	1	561-0017	Gas solenoid 24V
7	1	753-3285	Adptr FE 5/8-18 to M 1/8 NPT
8	2.50 FT	844-0089	Cable 22GA/2CNDT flex

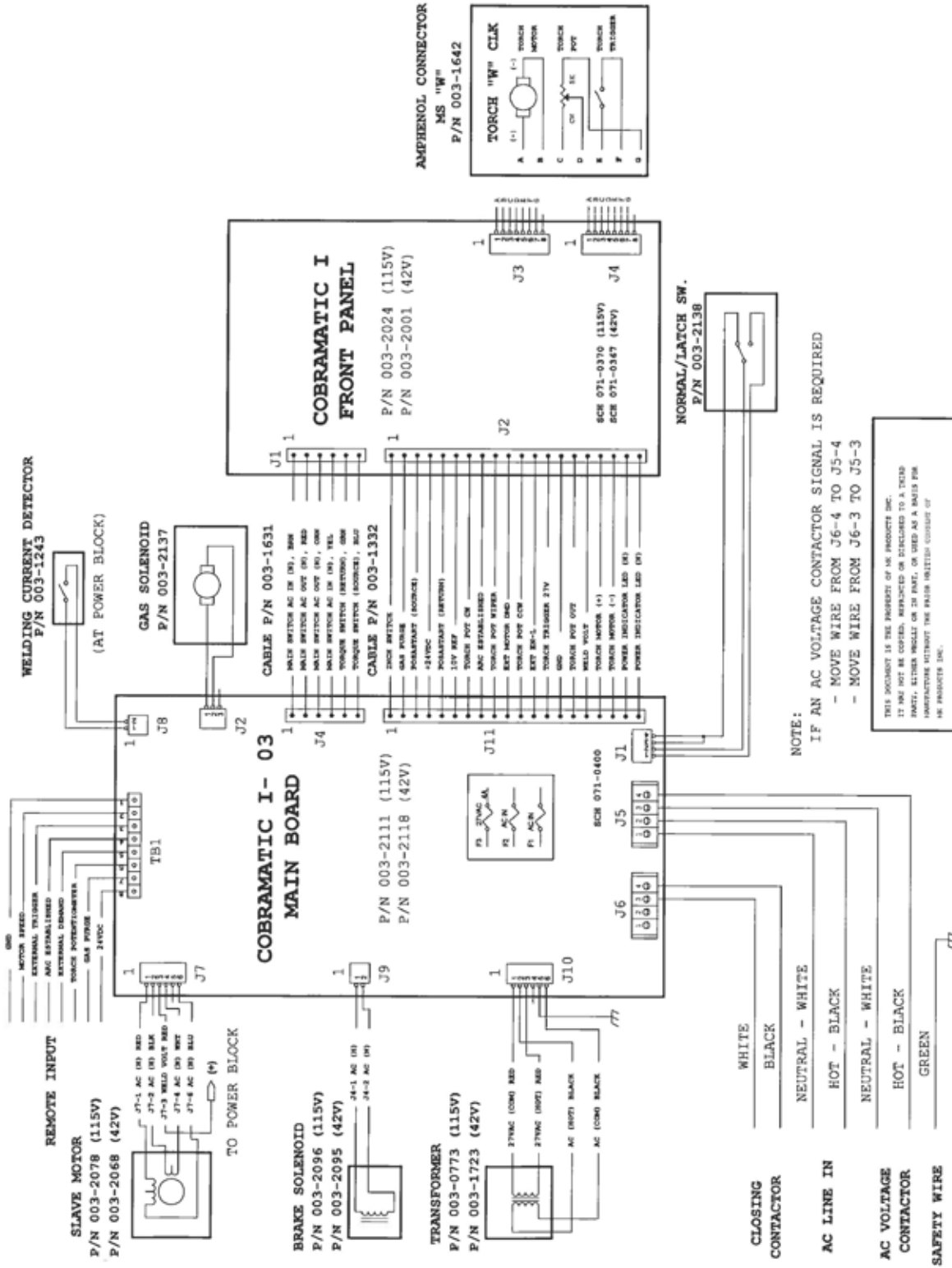

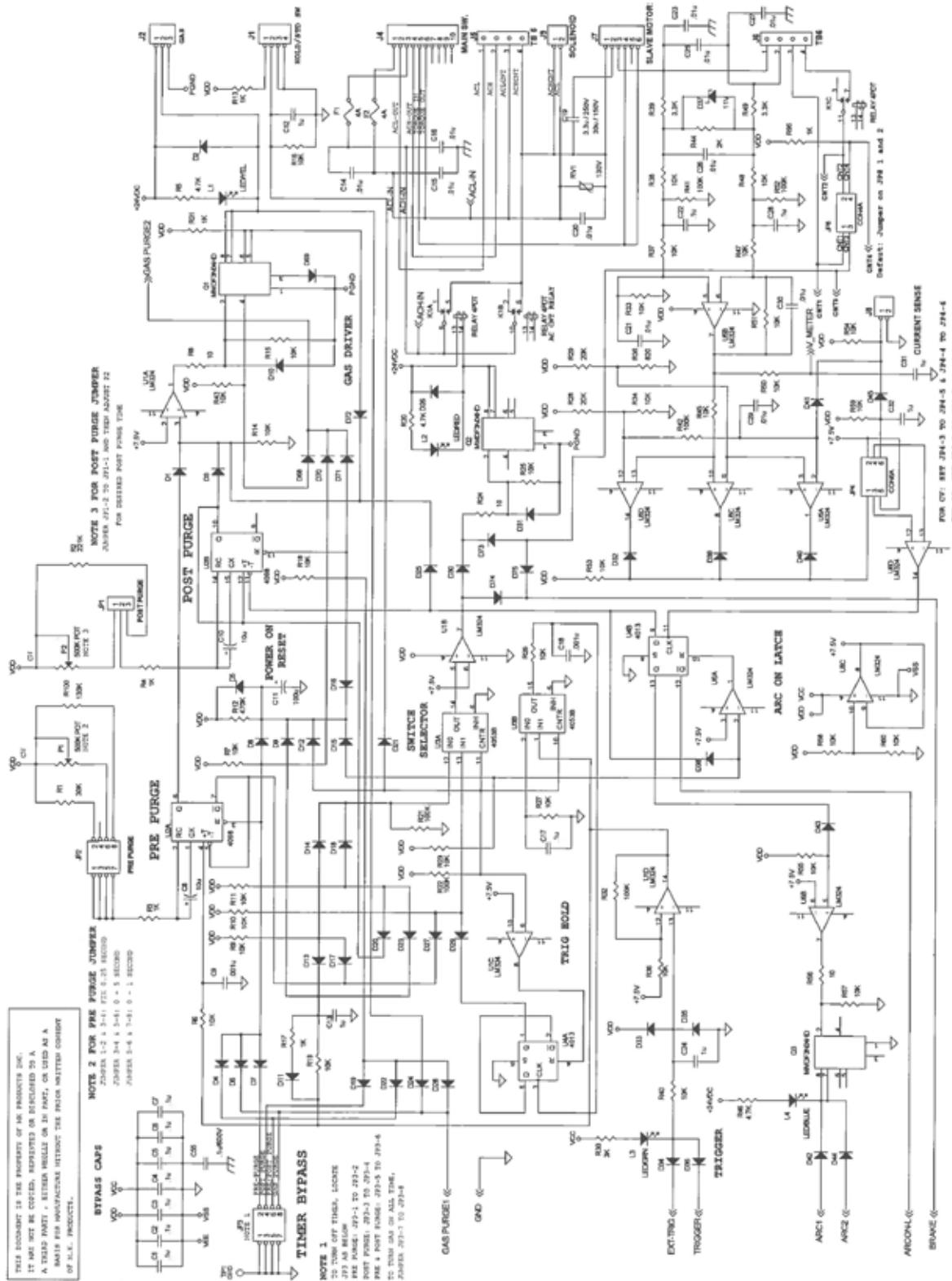

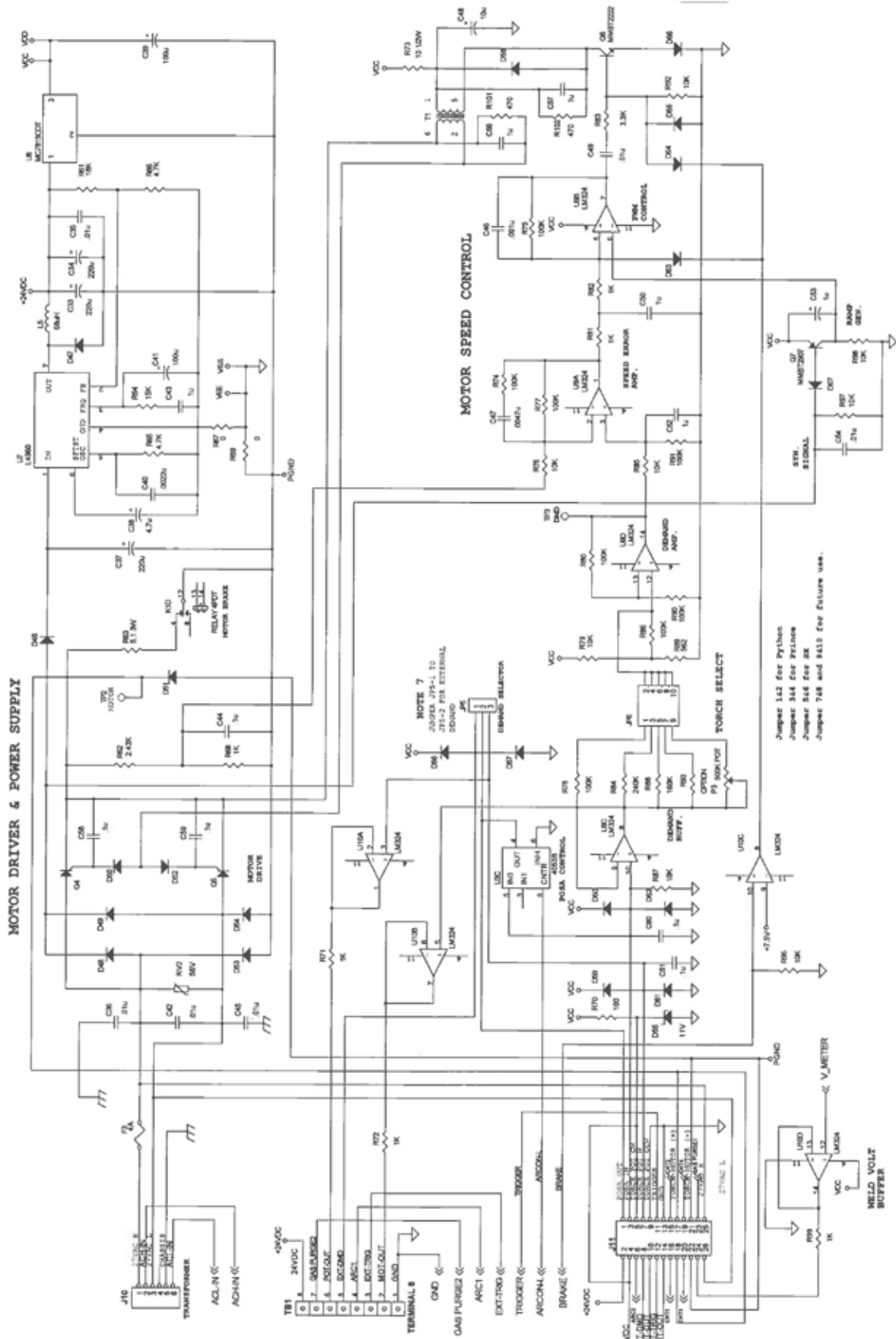

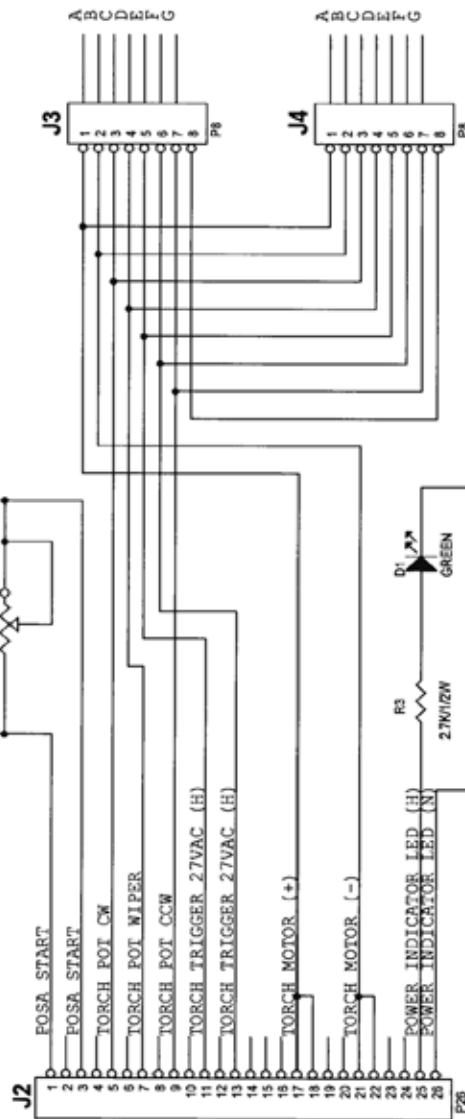
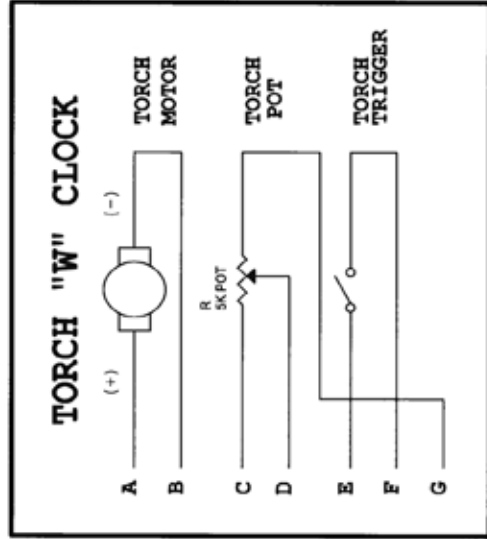
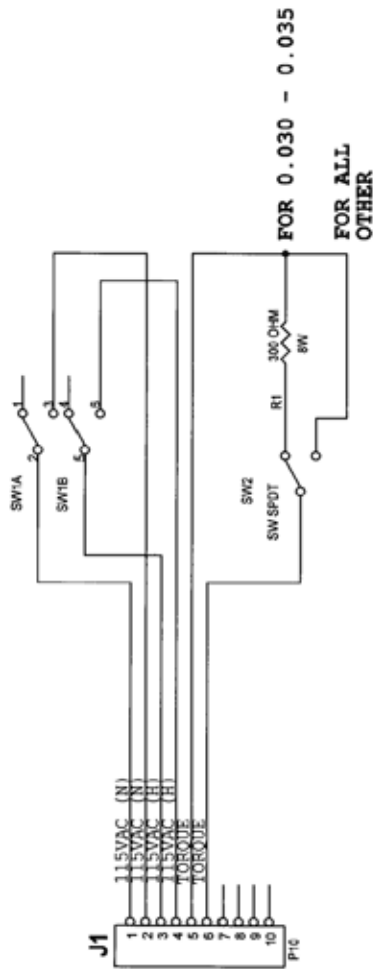

INPUT / OUTPUT CONFIGURATION FOR TB1

Monitor Wire Feed Speed

Use digital volt meter between: TB1 – 1(GND) and TB1 – 2(MSPD).

Measured value defined as: Reading x 100 = Wire Feed Speed.

Example: 3.54 VDC is equivalent to 354 IPM

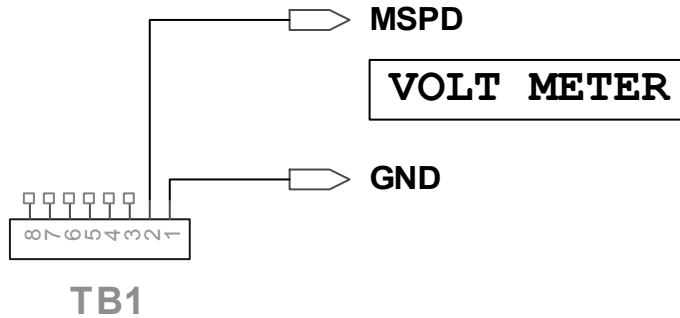

Remote/External Trigger

Install jumper between: TB1 – 1(GND) and TB1 – 3(TRIG) to trigger system.

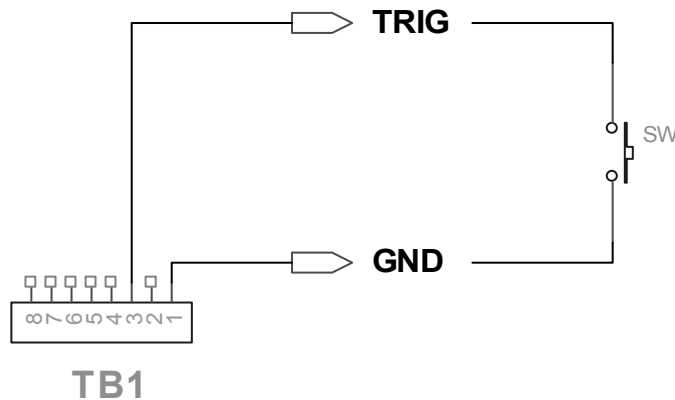

Arc Establish Relay Closure

External Contact Signal; Connect 24VDC relay coil between TB1 – 8 (24V) and TB1 – 4 (ARC). When arc is established, the relay coil will close.

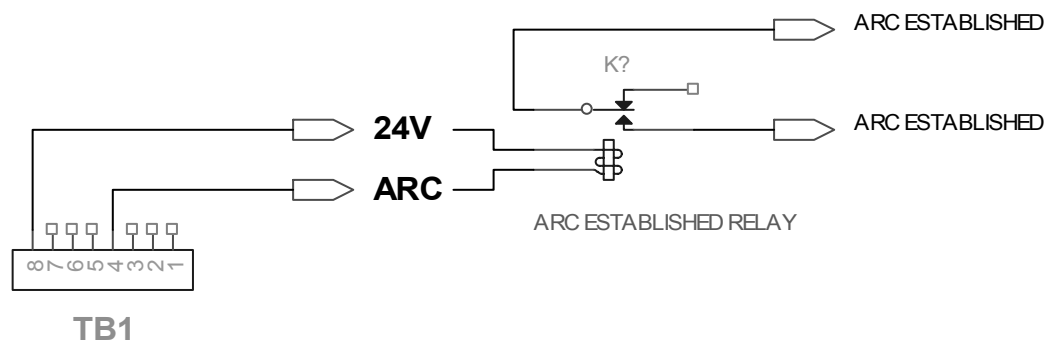

External Motor Speed Control

To control the motor wire feed speed using an external source of DC voltage, other than from the board itself. Relocate JP5 jumper from bottom position (Internal-GUN) to upper position (External-POT). Connect external DC voltage between TB1 – 1 (GND) and TB1 – 5 (DMD) .

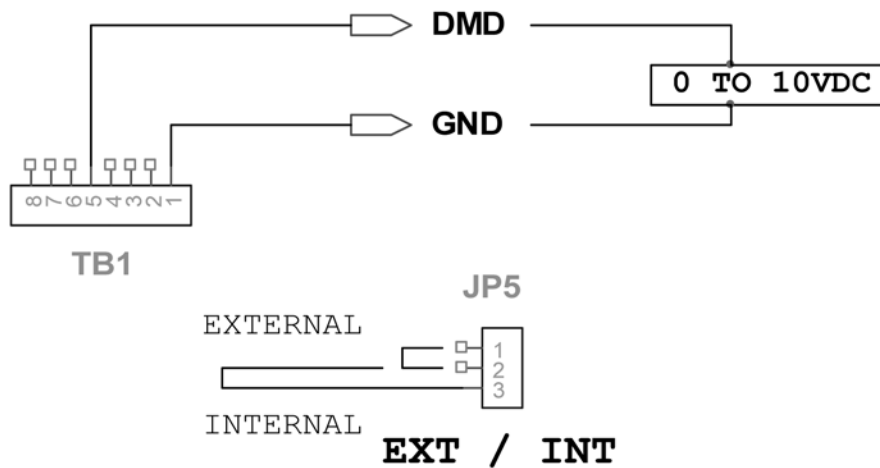

Torch Pot Output

Some power supplies can utilize a variable DC voltage signal from the gun potentiometer adjustment as their external voltage control. Adjusting the potentiometer at the gun will give 0 to 10VDC output between TB1 – 1 (GND) and TB1 – 6 (POT).

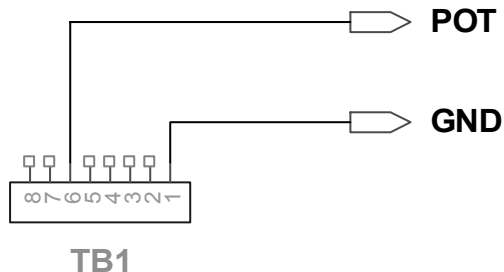

A common “synergic” type of setup is to have the gun potentiometer signal control the welding voltage of the welding power supply. As this external signal adjusts the voltage up or down, its external 0-10VDC signal can come back into TB-1, as shown below in External Motor Speed Control, and control the wire feed speed.

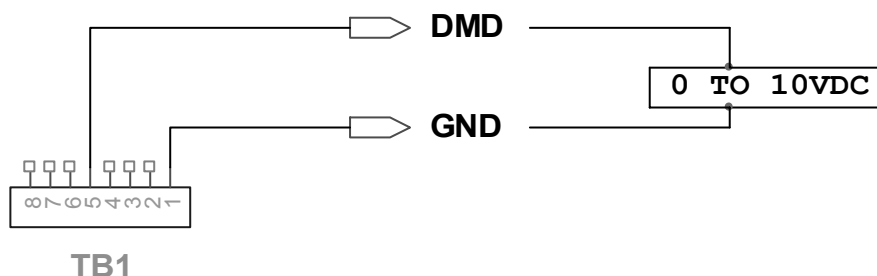

This is mainly dependant on the configuration and signal adaptation of the welding power supply. Check with your welding equipment manufacturer to see if your welding power source has this feature or can adapt to this type of setup. Not all welding power sources can do this.

Manual Gas Purge

Jumper from TB1-7 to TB1-1 to externally operate the gas solenoid in the cabinet.

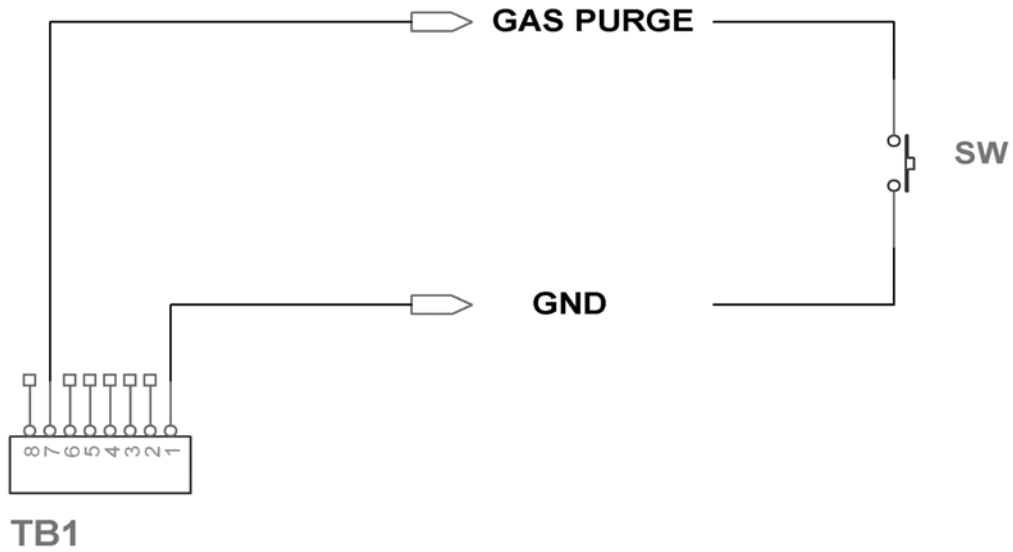

			
WARNING	<ul style="list-style-type: none"> ● Do not touch electrically live parts or electrode with skin or wet clothing. ● Insulate yourself from work and ground. 	<ul style="list-style-type: none"> ● Keep flammable materials away. 	<ul style="list-style-type: none"> ● Wear eye, ear and body protection.
Spanish AVISO DE PRECAUCION	<ul style="list-style-type: none"> ● No toque las partes o los electrodos bajo carga con la piel o ropa mojada. ● Aíslese del trabajo y de la tierra. 	<ul style="list-style-type: none"> ● Mantenga el material combustible fuera del área de trabajo. 	<ul style="list-style-type: none"> ● Protéjase los ojos, los oídos y el cuerpo.
French ATTENTION	<ul style="list-style-type: none"> ● Ne laissez ni la peau ni des vêtements mouillés entrer en contact avec des pièces sous tension. ● Isolez-vous du travail et de la terre. 	<ul style="list-style-type: none"> ● Gardez à l'écart de tout matériel inflammable. 	<ul style="list-style-type: none"> ● Protégez vos yeux, vos oreilles et votre corps.
German WARNUNG	<ul style="list-style-type: none"> ● Berühren Sie keine stromführenden Teile oder Elektroden mit Ihrem Körper oder feuchter Kleidung! ● Isolieren Sie sich von den Elektroden und dem Erdboden! 	<ul style="list-style-type: none"> ● Entfernen Sie brennbares Material! 	<ul style="list-style-type: none"> ● Tragen Sie Augen-, Ohren- und Körperschutz!
Portuguese ATENÇÃO	<ul style="list-style-type: none"> ● Não toque partes elétricas e electrodos com a pele ou roupa molhada. ● Isole-se da peça e terra. 	<ul style="list-style-type: none"> ● Mantenha inflamáveis bem guardados. 	<ul style="list-style-type: none"> ● Use proteção para a vista, ouvido e corpo.
Japanese 注意事項	<ul style="list-style-type: none"> ● 通電中の電気部品、又は溶材にヒフやぬれた布で触れないこと。 ● 施工物やアースから身体が絶縁されている様にして下さい。 	<ul style="list-style-type: none"> ● 燃えやすいものの側での溶接作業は絶対にしてはなりません。 	<ul style="list-style-type: none"> ● 目、耳及び身体に保護具をして下さい。
Chinese 警告	<ul style="list-style-type: none"> ● 皮肤或湿衣物切勿接触带电部件及焊缝。 ● 使你自己与地面和工件绝缘。 	<ul style="list-style-type: none"> ● 把一切易燃物品移离工作场所。 	<ul style="list-style-type: none"> ● 佩戴眼、耳及身体劳动保护用具。
Korean 위험	<ul style="list-style-type: none"> ● 전도체나 용접봉을 젖은 황급 또는 피부로 절대 접촉치 마십시오. ● 모재와 접지를 접촉치 마십시오. 	<ul style="list-style-type: none"> ● 인화성 물질을 접근시키지 마십시오. 	<ul style="list-style-type: none"> ● 눈, 귀와 몸에 보호장구를 착용하십시오.
Arabic تحذير	<ul style="list-style-type: none"> ● لا تلمس الأجزاء التي يسري فيها التيار الكهربائي أو الأقطاب بجهد الجسم أو الملابس المبللة بالماء. ● ضع عازلا على جسمك خلال العمل. 	<ul style="list-style-type: none"> ● ضع المواد القابلة للاشتعال في مكان بعيد. 	<ul style="list-style-type: none"> ● ضع أدوات وملابس واقية على عينيك وأذنيك وجسمك.

READ AND UNDERSTAND THE MANUFACTURER'S INSTRUCTION FOR THIS EQUIPMENT AND THE CONSUMABLES TO BE USED AND FOLLOW YOUR EMPLOYER'S SAFETY PRACTICES.

SE RECOMIENDA LEER Y ENTENDER LAS INSTRUCCIONES DEL FABRICANTE PARA EL USO DE ESTE EQUIPO Y LOS CONSUMIBLES QUE VA A UTILIZAR, SIGA LAS MEDIDAS DE SEGURIDAD DE SU SUPERVISOR.

LISEZ ET COMPRENEZ LES INSTRUCTIONS DU FABRICANT EN CE QUI REGARDE CET EQUIPMENT ET LES PRODUITS A ETRE EMPLOYES ET SUIVEZ LES PROCEDURES DE SECURITE DE VOTRE EMPLOYEUR.

LESEN SIE UND BEFOLGEN SIE DIE BETRIEBSANLEITUNG DER ANLAGE UND DEN ELEKTRODENEINSATZ DES HERSTELLERS. DIE UNFALLVERHÜTUNGSVORSCHRIFTEN DES ARBEITGEBERS SIND EBENFALLS ZU BEACHTEN.

			
<ul style="list-style-type: none"> ● Keep your head out of fumes. ● Use ventilation or exhaust to remove fumes from breathing zone. 	<ul style="list-style-type: none"> ● Turn power off before servicing. 	<ul style="list-style-type: none"> ● Do not operate with panel open or guards off. 	WARNING
<ul style="list-style-type: none"> ● Los humos fuera de la zona de respiración. ● Mantenga la cabeza fuera de los humos. Utilice ventilación o aspiración para gases. 	<ul style="list-style-type: none"> ● Desconectar el cable de alimentación de poder de la máquina antes de iniciar cualquier servicio. 	<ul style="list-style-type: none"> ● No operar con panel abierto o guardas quitadas. 	Spanish AVISO DE PRECAUCION
<ul style="list-style-type: none"> ● Gardez la tête à l'écart des fumées. ● Utilisez un ventilateur ou un aspirateur pour ôter les fumées des zones de travail. 	<ul style="list-style-type: none"> ● Débranchez le courant avant l'entretien. 	<ul style="list-style-type: none"> ● N'opérez pas avec les panneaux ouverts ou avec les dispositifs de protection enlevés. 	French ATTENTION
<ul style="list-style-type: none"> ● Vermeiden Sie das Einatmen von Schweißrauch! ● Sorgen Sie für gute Be- und Entlüftung des Arbeitsplatzes! 	<ul style="list-style-type: none"> ● Strom vor Wartungsarbeiten abschalten! (Netzstrom völlig öffnen; Maschine anhalten!) 	<ul style="list-style-type: none"> ● Anlage nie ohne Schutzgehäuse oder Innenschutzverkleidung in Betrieb setzen! 	German WARNUNG
<ul style="list-style-type: none"> ● Mantenha seu rosto da fumaça. ● Use ventilação e exaustão para remover fumo da zona respiratória. 	<ul style="list-style-type: none"> ● Não opere com as tampas removidas. ● Desligue a corrente antes de fazer serviço. ● Não toque as partes elétricas nuas. 	<ul style="list-style-type: none"> ● Mantenha-se afastado das partes moventes. ● Não opere com os painéis abertos ou guardas removidas. 	Portuguese ATENÇÃO
<ul style="list-style-type: none"> ● ヒュームから頭を離すようにして下さい。 ● 換気や排煙に十分留意して下さい。 	<ul style="list-style-type: none"> ● メンテナンス・サービスに取りかかる際には、まず電源スイッチを必ず切って下さい。 	<ul style="list-style-type: none"> ● パネルやカバーを取り外したまま機械操作をしないで下さい。 	Japanese 注意事項
<ul style="list-style-type: none"> ● 頭部遠離煙霧。 ● 在呼吸區使用通風或排風器除煙。 	<ul style="list-style-type: none"> ● 維修前切斷電源。 	<ul style="list-style-type: none"> ● 儀表板打開或沒有安全罩時不準作業。 	Chinese 警告
<ul style="list-style-type: none"> ● 얼굴로부터 용접가스를 멀리하십시오. ● 호흡지역으로부터 용접가스를 제거하기 위해 가스제거기나 통풍기를 사용하십시오. 	<ul style="list-style-type: none"> ● 보수전에 전원을 차단하십시오. 	<ul style="list-style-type: none"> ● 판넬이 열린 상태로 작동처 마십시오. 	Korean 위험
<ul style="list-style-type: none"> ● ابعد رأسك بعيداً عن الدخان. ● استعمل التهوية أو جهاز ضغط الدخان للخارج لكي تبعد الدخان عن المنطقة التي تتنفس فيها. 	<ul style="list-style-type: none"> ● اقطع التيار الكهربائي قبل القيام بأية صيانة. 	<ul style="list-style-type: none"> ● لا تشغيل هذا الجهاز اذا كانت الاغطية الحديدية الوالفة ليست عليه. 	Arabic تحذير

LEIA E COMPREENDA AS INSTRUÇÕES DO FABRICANTE PARA ESTE EQUIPAMENTO E AS PARTES DE USO, E SIGA AS PRÁTICAS DE SEGURANÇA DO EMPREGADOR.

使う機械や溶材のメーカーの指示書をよく読み、まず理解して下さい。そして貴社の安全規定に従って下さい。

請詳細閱讀並理解製造廠提供的說明以及應該使用的銀焊材料，並請遵守貴方的有關勞動保護規定。

이 제품에 동봉된 작업지침서를 숙지하시고 귀사의 작업자 안전수칙을 준수하시기 바랍니다.

اقرأ بتمعن وافهم تعليمات المصنع المنتج لهذه المعدات والمواد قبل استعمالها واتبع تعليمات الوقاية لصاحب العمل.

LIMITED WARRANTY

Effective August 1, 2008

This warranty supersedes all previous MK Products warranties and is exclusive, with no other guarantees or warranties expressed or implied.

LIMITED WARRANTY - MK Products Inc., Irvine, California warrants that all new and unused equipment furnished by MK Products is free from defects in workmanship and material as of the time and place of delivery by MK Products. No warranty is made by MK Products with respect to trade accessories or other items manufactured by others. Such trade accessories and other items are sold subject to the warranties of their respective manufacturers, if any.

MK Products' warranty does not apply to components having normal useful life of less than one (1) year, such as relay points, wire conduit, tungsten, and welding gun parts that come in contact with the welding wire, including gas cups, gas cup insulators, and contact tips where failure does not result from defect in workmanship or material.

MK Products shall, exclusively remedy the limited warranty or any duties with respect to the quality of goods, based upon the following options:

- (1) repair
- (2) replacement
- (3) where authorized in writing by MK Products, the reasonable cost of repair or replacement at our Irvine, California plant.

As a matter of general policy only, MK Products may honor an original user's warranty claims on warranted equipment in the event of failure resulting from a defect within the following periods from the date of delivery of equipment to the original user:

- 1. Power Supplies and Wire Feed Cabinets 3 years
- 2. Weldheads, CobraCooler, Positioners, Prince XL and Prince XL Spool Guns, Python, CobraMAX, Cobra SX, Cobra MX 1 year
- 3. Sidewinder Spool Gun, Prince SG Spool Guns, Modules 180 days
- 4. Repairs/Exchanges/Parts/Accessories 90 days

Classification of any item into the foregoing categories shall be at the sole discretion of MK Products. Notification of any failure must be made in writing within 30 days of such failure.

A copy of the invoice showing the date of sale must accompany products returned for warranty repair or replacement.

All equipment returned to MK Products for service must be properly packaged to guard against damage from shipping. MK Products will not be responsible for any damages resulting from shipping.

Normal surface transportation charges (one way) for products returned for warranty repair or replacement will be borne by MK Products, except for products sold to foreign markets.

ANY EXPRESS WARRANTY NOT PROVIDED HEREIN AND ANY IMPLIED WARRANTY, GUARANTY, OR REPRESENTATION AS TO PERFORMANCE, AND ANY REMEDY FOR BREACH OF CONTRACT WHICH, BUT FOR THIS PROVISION, MIGHT ARISE BY IMPLICATION, OPERATION OF LAW, CUSTOM OF TRADE, OR COURSE OF DEALING, INCLUDING ANY IMPLIED WARRANTY OF MERCHANTABILITY OR OF FITNESS FOR PARTICULAR PURPOSE, WITH RESPECT TO ANY AND ALL EQUIPMENT FURNISHED BY MK PRODUCTS, IS EXCLUDED AND DISCLAIMED BY MK PRODUCTS.

EXCEPT AS EXPRESSLY PROVIDED BY MK PRODUCTS IN WRITING, MK'S PRODUCTS ARE INTENDED FOR ULTIMATE PURCHASE BY COMMERCIAL/INDUSTRIAL USERS AND FOR OPERATION BY PERSONS TRAINED AND EXPERIENCED IN THE USE AND MAINTENANCE OF WELDING EQUIPMENT AND NOT FOR CONSUMERS OR CONSUMER USE. MK PRODUCTS' WARRANTIES DO NOT EXTEND TO, AND NO RE-SELLER IS AUTHORIZED TO EXTEND MK PRODUCTS' WARRANTIES TO ANY CONSUMER.

USE OF OTHER THAN *GENUINE* MK PRODUCTS' CONSUMABLES, PARTS, AND ACCESSORIES MAY INVALIDATE YOUR PRODUCT WARRANTY.



16882 Armstrong Ave
Irvine, CA 92606
Tel (949) 863-1234
Fax (949) 474-1428
www.mkproducts.com

August 1, 2008
Rev. A



16882 Armstrong Ave.
Irvine, California 92606
Tel 949.863.1234
Fax 949.474.1428
www.mkproducts.com