



PYTHON[®]
Lincoln Compatible™

Owner's Manual

Product:	Python
Manual:	091-0618
Serial:	10080001
Voltage Rating:	24 VDC
Revision:	August 2010 Rev B
Gun models:	232-8XX 293-8XX



225 Ampere Air Cooled
450 Ampere Water Cooled
Push-Pull Welding Guns

Table of Contents

Safety Considerations i-iii

Installation Section A

 Technical Specifications 1

 Support Equipment Required 1

 Gun Lead Connections 1

Operation Section B

 General 2

 Controls and Settings 2

 Trigger Adjustment 2

 Drive Roll and Idler Rolls 3

Accessories Section C

 Optional Kits 3

 Snake Skins 4

 Contact Tips 4

 Gas Cups 5

 Barrels 5

Maintenance Section D

 Periodic Maintenance 6

 Recommended Spare Parts List 7

Troubleshooting Section E

 Troubleshooting Guide 9

 Testing The Gun 9

Appendices Section F

 Diagrams / Parts List 11

 Mechanical 12

 Electrical 27

Safety Warnings

Warranty

Declaration of Conformity for European Community (CE) Products

Note  This information is provided for units with CE certification (see rating label on unit).

Manufacturer's Name: **MK Products, Inc.**
16882 Armstrong Ave.
Irvine, CA 92606

Declares that the product: **Python[®] Lincoln Compatible**
conforms to the following Directives and Standards:

Directives

Low Voltage Directive: 2006/95/EC

Electromagnetic Compatibility (EMC) Directive: 2004/108/EC

Standards

Electromagnetic Compatibility, (EMC): EN 60974-10: 2007

Torches And Guns For Arc Welding, EN 60974-7: 2005

SAFETY

⚠ WARNING

⚠ CALIFORNIA PROPOSITION 65 WARNINGS ⚠

Diesel engine exhaust and some of its constituents are known to the State of California to cause cancer, birth defects, and other reproductive harm.

The Above For Diesel Engines

The engine exhaust from this product contains chemicals known to the State of California to cause cancer, birth defects, or other reproductive harm.

The Above For Gasoline Engines

ARC WELDING CAN BE HAZARDOUS. PROTECT YOURSELF AND OTHERS FROM POSSIBLE SERIOUS INJURY OR DEATH. KEEP CHILDREN AWAY. PACEMAKER WEARERS SHOULD CONSULT WITH THEIR DOCTOR BEFORE OPERATING.

Read and understand the following safety highlights. For additional safety information, it is strongly recommended that you purchase a copy of "Safety in Welding & Cutting - ANSI Standard Z49.1" from the American Welding Society, P.O. Box 351040, Miami, Florida 33135 or CSA Standard W117.2-1974. A Free copy of "Arc Welding Safety" booklet E205 is available from the Lincoln Electric Company, 22801 St. Clair Avenue, Cleveland, Ohio 44117-1199.

BE SURE THAT ALL INSTALLATION, OPERATION, MAINTENANCE AND REPAIR PROCEDURES ARE PERFORMED ONLY BY QUALIFIED INDIVIDUALS.



FOR ENGINE powered equipment.

1.a. Turn the engine off before troubleshooting and maintenance work unless the maintenance work requires it to be running.



1.b. Operate engines in open, well-ventilated areas or vent the engine exhaust fumes outdoors.



1.c. Do not add the fuel near an open flame welding arc or when the engine is running. Stop the engine and allow it to cool before refueling to prevent spilled fuel from vaporizing on contact with hot engine parts and igniting. Do not spill fuel when filling tank. If fuel is spilled, wipe it up and do not start engine until fumes have been eliminated.

1.d. Keep all equipment safety guards, covers and devices in position and in good repair. Keep hands, hair, clothing and tools away from V-belts, gears, fans and all other moving parts when starting, operating or repairing equipment.

1.e. In some cases it may be necessary to remove safety guards to perform required maintenance. Remove guards only when necessary and replace them when the maintenance requiring their removal is complete. Always use the greatest care when working near moving parts.



1.f. Do not put your hands near the engine fan. Do not attempt to override the governor or idler by pushing on the throttle control rods while the engine is running.

1.g. To prevent accidentally starting gasoline engines while turning the engine or welding generator during maintenance work, disconnect the spark plug wires, distributor cap or magneto wire as appropriate.



1.h. To avoid scalding, do not remove the radiator pressure cap when the engine is hot.



ELECTRIC AND MAGNETIC FIELDS may be dangerous

2.a. Electric current flowing through any conductor causes localized Electric and Magnetic Fields (EMF). Welding current creates EMF fields around welding cables and welding machines

2.b. EMF fields may interfere with some pacemakers, and welders having a pacemaker should consult their physician before welding.

2.c. Exposure to EMF fields in welding may have other health effects which are now not known.

2.d. All welders should use the following procedures in order to minimize exposure to EMF fields from the welding circuit:

2.d.1. Route the electrode and work cables together - Secure them with tape when possible.

2.d.2. Never coil the electrode lead around your body.

2.d.3. Do not place your body between the electrode and work cables. If the electrode cable is on your right side, the work cable should also be on your right side.

2.d.4. Connect the work cable to the workpiece as close as possible to the area being welded.

2.d.5. Do not work next to welding power source.



ELECTRIC SHOCK can kill.

- 3.a. The electrode and work (or ground) circuits are electrically "hot" when the welder is on. Do not touch these "hot" parts with your bare skin or wet clothing. Wear dry, hole-free gloves to insulate hands.
- 3.b. Insulate yourself from work and ground using dry insulation. Make certain the insulation is large enough to cover your full area of physical contact with work and ground.
- In addition to the normal safety precautions, if welding must be performed under electrically hazardous conditions (in damp locations or while wearing wet clothing; on metal structures such as floors, gratings or scaffolds; when in cramped positions such as sitting, kneeling or lying, if there is a high risk of unavoidable or accidental contact with the workpiece or ground) use the following equipment:**
- Semiautomatic DC Constant Voltage (Wire) Welder.
 - DC Manual (Stick) Welder.
 - AC Welder with Reduced Voltage Control.
- 3.c. In semiautomatic or automatic wire welding, the electrode, electrode reel, welding head, nozzle or semiautomatic welding gun are also electrically "hot".
- 3.d. Always be sure the work cable makes a good electrical connection with the metal being welded. The connection should be as close as possible to the area being welded.
- 3.e. Ground the work or metal to be welded to a good electrical (earth) ground.
- 3.f. Maintain the electrode holder, work clamp, welding cable and welding machine in good, safe operating condition. Replace damaged insulation.
- 3.g. Never dip the electrode in water for cooling.
- 3.h. Never simultaneously touch electrically "hot" parts of electrode holders connected to two welders because voltage between the two can be the total of the open circuit voltage of both welders.
- 3.i. When working above floor level, use a safety belt to protect yourself from a fall should you get a shock.
- 3.j. Also see Items 6.c. and 8.



ARC RAYS can burn.

- 4.a. Use a shield with the proper filter and cover plates to protect your eyes from sparks and the rays of the arc when welding or observing open arc welding. Headshield and filter lens should conform to ANSI Z87.1 standards.
- 4.b. Use suitable clothing made from durable flame-resistant material to protect your skin and that of your helpers from the arc rays.
- 4.c. Protect other nearby personnel with suitable, non-flammable screening and/or warn them not to watch the arc nor expose themselves to the arc rays or to hot spatter or metal.



FUMES AND GASES can be dangerous.

- 5.a. Welding may produce fumes and gases hazardous to health. Avoid breathing these fumes and gases. When welding, keep your head out of the fume. Use enough ventilation and/or exhaust at the arc to keep fumes and gases away from the breathing zone. **When welding with electrodes which require special ventilation such as stainless or hard facing (see instructions on container or MSDS) or on lead or cadmium plated steel and other metals or coatings which produce highly toxic fumes, keep exposure as low as possible and within applicable OSHA PEL and ACGIH TLV limits using local exhaust or mechanical ventilation. In confined spaces or in some circumstances, outdoors, a respirator may be required. Additional precautions are also required when welding on galvanized steel.**
5. b. The operation of welding fume control equipment is affected by various factors including proper use and positioning of the equipment, maintenance of the equipment and the specific welding procedure and application involved. Worker exposure level should be checked upon installation and periodically thereafter to be certain it is within applicable OSHA PEL and ACGIH TLV limits.
- 5.c. Do not weld in locations near chlorinated hydrocarbon vapors coming from degreasing, cleaning or spraying operations. The heat and rays of the arc can react with solvent vapors to form phosgene, a highly toxic gas, and other irritating products.
- 5.d. Shielding gases used for arc welding can displace air and cause injury or death. Always use enough ventilation, especially in confined areas, to insure breathing air is safe.
- 5.e. Read and understand the manufacturer's instructions for this equipment and the consumables to be used, including the material safety data sheet (MSDS) and follow your employer's safety practices. MSDS forms are available from your welding distributor or from the manufacturer.
- 5.f. Also see item 1.b.



WELDING and CUTTING SPARKS can cause fire or explosion.

6.a. Remove fire hazards from the welding area. If this is not possible, cover them to prevent the welding sparks from starting a fire.

Remember that welding sparks and hot materials from welding can easily go through small cracks and openings to adjacent areas. Avoid welding near hydraulic lines. Have a fire extinguisher readily available.

- 6.b. Where compressed gases are to be used at the job site, special precautions should be used to prevent hazardous situations. Refer to "Safety in Welding and Cutting" (ANSI Standard Z49.1) and the operating information for the equipment being used.
- 6.c. When not welding, make certain no part of the electrode circuit is touching the work or ground. Accidental contact can cause overheating and create a fire hazard.
- 6.d. Do not heat, cut or weld tanks, drums or containers until the proper steps have been taken to insure that such procedures will not cause flammable or toxic vapors from substances inside. They can cause an explosion even though they have been "cleaned". For information, purchase "Recommended Safe Practices for the Preparation for Welding and Cutting of Containers and Piping That Have Held Hazardous Substances", AWS F4.1 from the American Welding Society (see address above).
- 6.e. Vent hollow castings or containers before heating, cutting or welding. They may explode.
- 6.f. Sparks and spatter are thrown from the welding arc. Wear oil free protective garments such as leather gloves, heavy shirt, cuffless trousers, high shoes and a cap over your hair. Wear ear plugs when welding out of position or in confined places. Always wear safety glasses with side shields when in a welding area.
- 6.g. Connect the work cable to the work as close to the welding area as practical. Work cables connected to the building framework or other locations away from the welding area increase the possibility of the welding current passing through lifting chains, crane cables or other alternate circuits. This can create fire hazards or overheat lifting chains or cables until they fail.
- 6.h. Also see item 1.c.
- 6.i. Read and follow NFPA 51B "Standard for Fire Prevention During Welding, Cutting and Other Hot Work", available from NFPA, 1 Batterymarch Park, PO box 9101, Quincy, Ma 022690-9101.
- 6.j. Do not use a welding power source for pipe thawing.



CYLINDER may explode if damaged.

7.a. Use only compressed gas cylinders containing the correct shielding gas for the process used and properly operating regulators designed for the gas and pressure used. All hoses, fittings, etc. should be suitable for the application and maintained in good condition.

- 7.b. Always keep cylinders in an upright position securely chained to an undercarriage or fixed support.
- 7.c. Cylinders should be located:
 - Away from areas where they may be struck or subjected to physical damage.
 - A safe distance from arc welding or cutting operations and any other source of heat, sparks, or flame.
- 7.d. Never allow the electrode, electrode holder or any other electrically "hot" parts to touch a cylinder.
- 7.e. Keep your head and face away from the cylinder valve outlet when opening the cylinder valve.
- 7.f. Valve protection caps should always be in place and hand tight except when the cylinder is in use or connected for use.
- 7.g. Read and follow the instructions on compressed gas cylinders, associated equipment, and CGA publication P-1, "Precautions for Safe Handling of Compressed Gases in Cylinders," available from the Compressed Gas Association 1235 Jefferson Davis Highway, Arlington, VA 22202.



FOR ELECTRICALLY powered equipment.

- 8.a. Turn off input power using the disconnect switch at the fuse box before working on the equipment.
- 8.b. Install equipment in accordance with the U.S. National Electrical Code, all local codes and the manufacturer's recommendations.
- 8.c. Ground the equipment in accordance with the U.S. National Electrical Code and the manufacturer's recommendations.

PRÉCAUTIONS DE SÛRETÉ

Pour votre propre protection lire et observer toutes les instructions et les précautions de sûreté spécifiques qui paraissent dans ce manuel aussi bien que les précautions de sûreté générales suivantes:

Sûreté Pour Soudage A L'Arc

1. Protégez-vous contre la secousse électrique:
 - a. Les circuits à l'électrode et à la pièce sont sous tension quand la machine à souder est en marche. Éviter toujours tout contact entre les parties sous tension et la peau nue ou les vêtements mouillés. Porter des gants secs et sans trous pour isoler les mains.
 - b. Faire très attention de bien s'isoler de la masse quand on soude dans des endroits humides, ou sur un plancher métallique ou des grilles métalliques, principalement dans les positions assis ou couché pour lesquelles une grande partie du corps peut être en contact avec la masse.
 - c. Maintenir le porte-électrode, la pince de masse, le câble de soudage et la machine à souder en bon et sûr état de fonctionnement.
 - d. Ne jamais plonger le porte-électrode dans l'eau pour le refroidir.
 - e. Ne jamais toucher simultanément les parties sous tension des porte-électrodes connectés à deux machines à souder parce que la tension entre les deux pinces peut être le total de la tension à vide des deux machines.
 - f. Si on utilise la machine à souder comme une source de courant pour soudage semi-automatique, ces précautions pour le porte-électrode s'appliquent aussi au pistolet de soudage.
2. Dans le cas de travail au dessus du niveau du sol, se protéger contre les chutes dans le cas où on reçoit un choc. Ne jamais enrouler le câble-électrode autour de n'importe quelle partie du corps.
3. Un coup d'arc peut être plus sévère qu'un coup de soleil, donc:
 - a. Utiliser un bon masque avec un verre filtrant approprié ainsi qu'un verre blanc afin de se protéger les yeux du rayonnement de l'arc et des projections quand on soude ou quand on regarde l'arc.
 - b. Porter des vêtements convenables afin de protéger la peau de soudeur et des aides contre le rayonnement de l'arc.
 - c. Protéger l'autre personnel travaillant à proximité au soudage à l'aide d'écrans appropriés et non-inflammables.
4. Des gouttes de laitier en fusion sont émises de l'arc de soudage. Se protéger avec des vêtements de protection libres de l'huile, tels que les gants en cuir, chemise épaisse, pantalons sans revers, et chaussures montantes.

5. Toujours porter des lunettes de sécurité dans la zone de soudage. Utiliser des lunettes avec écrans latéraux dans les zones où l'on pique le laitier.
6. Eloigner les matériaux inflammables ou les recouvrir afin de prévenir tout risque d'incendie dû aux étincelles.
7. Quand on ne soude pas, poser la pince à un endroit isolé de la masse. Un court-circuit accidentel peut provoquer un échauffement et un risque d'incendie.
8. S'assurer que la masse est connectée le plus près possible de la zone de travail qu'il est pratique de faire. Si on place la masse sur la charpente de la construction ou d'autres endroits éloignés de la zone de travail, on augmente le risque de voir passer le courant de soudage par les chaînes de levage, câbles de grue, ou autres circuits. Cela peut provoquer des risques d'incendie ou d'échauffement des chaînes et des câbles jusqu'à ce qu'ils se rompent.
9. Assurer une ventilation suffisante dans la zone de soudage. Ceci est particulièrement important pour le soudage de tôles galvanisées plombées, ou cadmiées ou tout autre métal qui produit des fumées toxiques.
10. Ne pas souder en présence de vapeurs de chlore provenant d'opérations de dégraissage, nettoyage ou pistolage. La chaleur ou les rayons de l'arc peuvent réagir avec les vapeurs du solvant pour produire du phosgène (gas fortement toxique) ou autres produits irritants.
11. Pour obtenir de plus amples renseignements sur la sûreté, voir le code "Code for safety in welding and cutting" CSA Standard W 117.2-1974.

PRÉCAUTIONS DE SÛRETÉ POUR LES MACHINES À SOUDER À TRANSFORMATEUR ET À REDRESSEUR

1. Relier à la terre le châssis du poste conformément au code de l'électricité et aux recommandations du fabricant. Le dispositif de montage ou la pièce à souder doit être branché à une bonne mise à la terre.
2. Autant que possible, l'installation et l'entretien du poste seront effectués par un électricien qualifié.
3. Avant de faire des travaux à l'intérieur de poste, la débrancher à l'interrupteur à la boîte de fusibles.
4. Garder tous les couvercles et dispositifs de sûreté à leur place.

Thank You

For selecting a quality product. We want you to take pride in operating this product...as much pride as we have in bringing the product to you!

Please Examine Carton and Equipment For Damage Immediately

When this equipment is shipped, title passes to the purchaser upon receipt by the carrier. Consequently, claims for material damaged in shipment must be made by the purchaser against the transportation company at the time the shipment is received.

Please record your equipment identification information below for future reference. This information can be found on your machine nameplate.

Model Name & Number _____

Code & Serial Number _____

Date of Purchase _____

Whenever you request replacements parts for, or information on this equipment always supply the information you have recorded above.

Read this Owner's Manual completely before attempting to use this equipment. Save this manual and keep it handy for quick reference. Pay particular attention to the safety instructions we have provided for your protection.

THIS PAGE INTENTIONALLY BLANK

Section A



Installation

Technical Specifications

Wire Capacity

.030" - .045" (0.6mm - 1.2mm) solid and hard wire

.030" - 1/16" (0.8mm - 1.6mm) aluminum and cored wire

Wire Speed

800 IPM (20.3 mpm) Max. at rated feeder Input Voltage (120VAC / 42VAC)

Duty Cycle - 60% (*All ratings are using Argon Gas*)

225 Amps/25 Volts Air Cooled

450 Amps/25 Volts Water Cooled

Support Equipment Required

- C.V. or C.C. Power Source of sufficient capacity for your needs.
- Regulated gas supply and hoses.
- Properly sized power leads from power source to wire feeder and ground.
- Water source and hose capable of providing a minimum of **1 quart (.95 liter) / min. at 45 p.s.i.** when using water cooled guns.

Coolant Recommendations

Use Cobra Coolant (Aluminum Protection), P/N 931-0060. Cobra Coolant does not contain reactive sulphur or chlorine and does not react with copper, brass or aluminum.

The coolant flow rate should be a minimum of 15 GPH (1 qt/min) between 35 and 45psi. Contact the re-circulator manufacturer for specifications on pressure.

Gun Lead Connections

Power Cable - Air Cooled

A #2 power cable is used on the Python® Lincoln Compatible™ gun. The gun and Power Pin ends of the cable are stripped to the copper strands and wrapped with a copper strip. A setscrew holds the cable securely in the gun body and in the Power Manifold with torque requirements of 55-60 in-lb.

Power Cable - Water Cooled

Python® Lincoln Compatible™ water cooled gun utilizes a power/water cable with a #6 AWG cable inside a 5/16" diameter hose. When water is used with this cable and the #10 water cooled gas cup (P/N 621-0065), the system is rated at 450 amps @ 60% duty cycle. The gun end is threaded into the gun body with torque requirements of 100±5 in-lb.

Conduit

The Python® Lincoln Compatible™ comes standard with a poly-lined conduit, for feeding aluminum wire. The longer fitting with a shallow groove is used on the gun end. A set screw located on top of the gun handle secures the conduit in place. The cabinet end of the conduit is secured into the Power Pin connector with a set screw.

Gas Hose

The gas hose is pushed over a barbed fitting on the end of the gun body and secured by twisting the hose retainer to the end of the hose (shown below). The hose retainer is re-usable and can be removed and re-installed as needed.



Section B

Coolant Connections

If so equipped, the ends of the coolant hose pushes over a barbed fitting on the end of the gun body and is secured by twisting the hose retainer to the end of the hose. The hose retainer is re-usable and can be removed and re-installed as needed.

The BLUE coolant supply hose pushes over a barbed fitting on the end of the gun body. The RED coolant return hose pushes over the barbed fitting in the Power Manifold. The opposite end of the RED hose connects to the return hose of the coolant recirculator.

Both the BLUE and RED threaded fittings on the end of the BLUE and RED hoses, are standard left-hand thread.

Control Cable

A multi-conductor control cable is used on the Python® Lincoln Compatible™ gun. The gun end of the cable is secured with a cable clamp and the wires are connected to the potentiometer, the micro switch, the motor and the gun body mechanically. Slack is left in the electric cable as it exits the back of the gun to prevent cable and/or wire breakage. The cabinet end of the control cable uses a 7-Pin, Amphenol connector.

Operation

General

The Python® Lincoln Compatible™ gun maintains a constant, steady, uniform wire feed speed, regardless of curved or looped wire conduit. The constant push exerted by the slave motor in the cabinet, combined with the pull of the gun motor, causes the wire to literally float friction-free through the wire conduit. The 24VDC gun motor is controlled by a three and three-quarter (3 3/4) turn potentiometer in the gun handle.

Controls and Settings

Potentiometer

The laterally-positioned potentiometer is located in the lower end of the handle, providing up to 800 ipm with 3 3/4 turns.

Micro Switch

The micro switch assembly consists of the micro switch, and leads.

Trigger Sensitivity

The amount of trigger level travel can be shortened for a "quicker" or "more responsive" action.

A more sensitive trigger lever is produced by reducing the gap between the trigger lever and the micro-switch lever. By turning-in the Trigger Sensitivity Adjustment Screw, it closed the gap between the trigger lever and the micro-switch lever.

This will enable the operator to increase the sensitivity of the trigger lever.

Sensitivity Adjustment

With the wire feeder turned on (with or without welding wire loaded), turn the screw in until the micro-switch is activated. Once activated, the gun and wire feeder motors will begin feeding wire. Retract the screw accordingly until the system is deactivated and adjusted to the operators' liking.

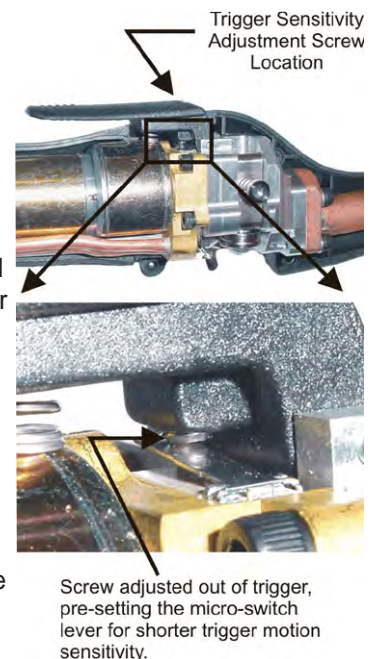

Drive Roll and Idler Rolls

General

The Python® Lincoln Compatible™ gun comes standard with a knurled drive roll and a grooved idler roll, which will handle aluminum wire with diameters of .030 to 1/16 inch and steel from .030 to .045 inches. Optional insulated V-groove drive rolls are also available for aluminum wire if desired (see Optional Kits).

Drive roll tension is accomplished with a unique spring-loaded pressure screw. The Python® Lincoln Compatible™ comes from the factory with the pressure adjustment screw preset. **NO ADJUSTMENT IS REQUIRED FOR ALL SIZES AND TYPES OF WIRES.**

Drive Roll Installation/Removal

NOTE: Neither of the handles needs to be removed to access the Drive or Idler Rolls.

1. Pull the Cam Lever away from the idler roll. This will relieve the pressure against the drive roll (as shown in Figure 1).



Figure 1

2. Align the Drive Roll Removal Tool (P/N 931-0100) over the flats of the drive roll (as shown in Figure 2). Hold the gun with one hand or on a table top, with the other hand give the Removal Tool a quick snap-turn in the **CLOCKWISE DIRECTION**.



Figure 2

3. Once the drive roll is loose, continue to spin drive roll in the clockwise direction to remove the drive roll from the gun.
4. Install a new drive roll on the left-hand threaded shaft. The drive roll will self-tighten when it is feeding wire.

Idler Roll Installation and Removal

(Reference Figure 3)

1. Using a slot type screwdriver, loosen idler screw, taking care not to lose lock washer under idler roll.
2. Insert new idler roll and lock washer onto screw, insuring that idler groove is toward top and lock washer is beneath.
3. Tighten.

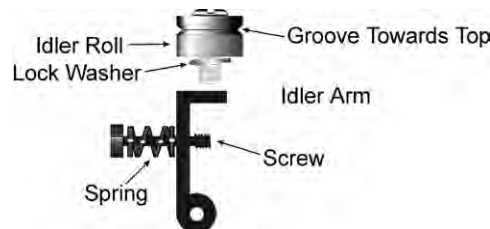

Figure 3

NOTE: Lock washer must be under idler roll or it will not turn freely.

Section C

Accessories/Options

Insulated Drive Roll Kits are used to prevent preheating of the wire which may soften it and clog the liner. This picking up of current at the drive rolls rather than at the contact tip is usually not a problem unless using too large of a contact tip or excessively oxidized aluminum wire.

Insulated Groove Drive Roll Kit..... 005-0640

For .030" (0.8mm) dia. aluminum wire. Includes insulated groove drive roll and insulated idler roll assy.

Insulated Groove Drive Roll Kit..... 005-0716

For .035" (0.9mm) dia. aluminum wire. Includes insulated groove drive roll and insulated idler roll assy.

Insulated Groove Drive Roll Kit..... 005-0717

For .040" (1.0mm) dia. aluminum wire. Includes insulated groove drive roll and insulated idler roll assy.

Insulated Groove Drive Roll Kit..... 005-0718

For 3/64" (1.2mm) dia. aluminum wire. Includes insulated groove drive roll and insulated idler roll assy.

Insulated Groove Drive Roll Kit..... 005-0644

For .062" (1.6mm) dia. aluminum wire. Includes insulated groove drive roll and insulated idler roll assy.

Handle Kit.....005-0699

Includes left and right handles, screws and drive roll door.

Trigger Kit.....005-0694

Trigger adjustment kit includes a spring and sensitivity adjustment screw replacement for all Python® Lincoln Compatible™ guns.

Micro Switch Kit.....005-0701

Replacement micro switch assembly for all Python® Lincoln Compatible™ guns.

Potentiometer Kit.....005-0695

Replacement potentiometer assembly for all Python® Lincoln Compatible™ guns.

Snake Skins®

Snake Skin® protective covers are now standard on all guns. You may order spare replacement covers to protect the lead assy of the gun when the factory one becomes damaged or worn. It can easily be replaced in the field by means of Velcro®.

Snake Skin Cover 13ft (for 15ft leads)931-0110

Snake Skin Cover 23ft (for 25ft leads) 931-0122

Snake Skin Cover 33ft (for 35ft leads) 931-0132

Snake Skin Cover 48ft (for 50ft leads) 931-0123

Contact Tips



Heavy Duty Contact Tip - 3/8" Diameter*				
Wire Size	Tip ID	Arc	Tip Length	Part No.
.030" (0.8mm)	.040" (1.0mm)	Spray	1.57" (39.9mm)	621-0390-25
		Short	1.82" (46.2mm)	621-0396-25
.035" (0.9mm)	.045" (1.1mm)	Spray	1.57" (39.9mm)	621-0391-25
				621-0391-250†
				621-0391-500††
.035" (0.9mm)	.045" (1.1mm)	Short	1.82" (46.2mm)	621-0397-25
.045" (1.1mm)	.054" (1.37mm)	Short	1.82" (46.2mm)	621-0398-25
3/64" (1.2mm)	.054" (1.37mm)	Spray	1.57" (39.9mm)	621-0392-25
				621-0392-250†
				621-0392-500††
3/64" (1.2mm)	.060" (1.5mm)	Spray	1.57" (39.9mm)	621-0393-25**
				621-0393-250†
				621-0393-500††
1/16" (1.6mm)	.074" (1.9mm)	Spray	1.57" (39.9mm)	621-0394-25
		Spray		621-0395-25

*Use of tip removal tool is recommended

† Also sold in quantities of 250

**This size tip furnished with gun

†† Also sold in quantities of 500

Finned Copper Cups



Finned Copper Gas Cups		
Cup Size	Cup I.D.	Part No.
No. 6	3/8" (9.5mm)	621-0248
No. 8	1/2" (12.7mm)	621-0249
No. 10	5/8" (15.8mm)	621-0250*

Heavy Duty Finned Copper Gas Cups		
Cup Size	Cup I.D.	Part No.
10	5/8" (15.8mm)	621-0251
12	3/4" (19.0mm)	621-0252

*Standard - furnished with Air Cooled gun

Air Cooled Cups for Python® Lincoln Compatible™ Water Cooled Gun		
Cup Size	Cup I.D.	Part No.
No. 6	3/8" (9.5mm)	621-0170
No. 8	1/2" (12.7mm)	621-0159
No. 10	5/8" (15.8mm)	621-0160

To use air cooled gas cups, you must use a cup retaining nut (449-0193) and a water cooled cup adapter (621-0101).

Water Cooled Cups for Python® Lincoln Compatible™ Water Cooled Gun		
Cup Size	Cup I.D.	Part No.
No. 10*	5/8" (15.9mm)	621-0065

*Standard - furnished with gun

Gun Barrel Liners	
Part Number	Description
931-0137	Teflon liner package, 5 pieces
615-0338	Steel wire only, .030 - .1/16" (0.8 - 0.9mm)
621-0424	Python® tip extender (Air cooled barrel only)
615-0250	Spiral steel liner for tip extender

Barrel Assemblies

All barrels are rated at 60% duty cycle.



225 Amps
Air Cooled, 60°
(P/N 003-2272)
Standard on AC

450 Amps
Water Cooled, 60°
(P/N 003-2317)
Standard on WC

225 Amp
Air/Water Cooled, 45°
(P/N 003-2152)
Optional on AC

300 Amps
Water Cooled
(P/N 003-2380)
Optional on WC

Barrels

Air Cooled

The Python® Lincoln Compatible™ air cooled gun comes standard with a 60° curved barrel. The barrel assembly locks to the gun body using the patented EZ Lock™ system.

Water Cooled

The Python Lincoln Compatible™ water cooled gun comes standard with a 60° curved water cooled barrel assembly.

Section D

Optional 6", 12" and 18" Straight and Curved Barrel Assemblies

12" Straight, Air Cooled Barrel Assembly	003-2332
12" Curved, 45° Air Cooled Barrel Assembly.....	003-2333
12" Straight, Water Cooled Barrel Assembly	003-2318
12" Curved, 45° Water Cooled Barrel Assembly.....	003-2319
18" Straight, Air Cooled Barrel Assembly	003-2334
18" Curved, 45° Air Cooled Barrel Assembly.....	003-2335
18" Straight Water Cooled Barrel Assembly	003-2320
18" Curved, 45° Water Cooled Barrel Assembly.....	003-2321

Barrel Removal and Installation

To remove the barrel assembly, loosen the patented EZ Lock™ Taper lock nut until it is clear of the threads. Pull barrel out of the gun body.

To replace a barrel assembly, open the drive and idler roll door and seat the barrel assembly until the inlet guide is almost touching the drive and idler roll and the rear face of the barrel is flush with the aluminum body block. Take care not to damage the "O" rings when inserting into the body. Tighten taper lock nut assembly firmly so that barrel cannot rotate.

Barrel Rotation

To rotate a barrel assembly, loosen the patented EZ Lock™ Taper lock nut assembly no more than 1 turn. Rotate barrel to the position of your choice and retighten taper lock nut assembly firmly so that the barrel cannot rotate.

WARNING: Do not attempt to weld without the barrel being tightly secured in the gun body, or damage to the barrel or body may result.

Maintenance

Periodic Maintenance

Your Cobramatic® System is designed to provide years of reliable service. Maintenance of the gun will normally consist of a general cleaning of the wire guide system, including barrels, drive rolls, and conduits at regular intervals.

Remove spatter build-up from inside of nozzles with a hardwood stick.

The only parts on the Cobramatic® system that are subject to normal wear are the conduit, contact tips, gas cups, front body liners, wire guides, drive and idler rolls. A supply of these parts should be maintained on hand.

The number of units in operation and the importance of minimal "down time" will determine to what extent spare parts should be stocked on hand. See the "Recommended Spare Parts List" for the most commonly replaced parts.

If repairs do become necessary, qualified shop maintenance personnel can easily replace any part.

Maintenance Tools

Tool	Part Number
Contact Tip Removal Tool	931-0002
Drive Roll Removal Tool	931-0100

Recommended Spare Parts List

Qty.	Part No.	Description
1	615-0620-15	Conduit - 15 ft
1	615-0620-25	Conduit - 25 ft
1	615-0620-35	Conduit - 35 ft
1	615-0620-50	Conduit - 50 ft
1	437-0253	Drive Roll Door
2	005-0694	Trigger Assy. Kit
2	005-0695	Potentiometer Kit
1	005-0699	Handle Kit
2	005-0701	Micro-Switch Kit
10	511-0101	Drive Roll
5	005-0686	Idler Roll Kit



DRIVE ROLL REMOVAL TOOL
931-0100



IDLER ROLL
005-0686



KNURLED DRIVE ROLL
511-0101



MICRO SWITCH ASSEMBLY
005-0701

Section E

Troubleshooting

Trouble	Cause	Remedy
No wire feed at gun, feeder not operating, i.e. no slave motor or brake solenoid.	115/42 VAC Control fuse in feeder/Control box blown.	Replace fuse.
	Micro-switch defective/not being activated.	Replace switch. Check switch for operation.
	Broken electrical cable.	Check micro-switch wires for continuity.
No wire feed at gun, feeder operating properly.	24 VAC Control fuse in feeder/Control box blown.	Check motor leads for shorts; then replace fuse.
	Bad potentiometer.	Check potentiometer with meter.
	Broken Electrical Cable.	Check motor and potentiometer wires for continuity.
Wire feeds, but welding wire is not energized.	Bad Speed control/PCB	See specific cabinet/control box owners manual for speed control operation.
	Loose or no cable connections.	Check all power connections.
	Contactors control cable loose or in wrong position.	Check power supply owners manual for location and type of contactor signal required.
Wire feeds erratically.	Welding power source.	Check power source.
	Dirty or worn conduit.	Blow out or replace conduit.
	Wrong size contact tip.	See Contact tip table.
Wire feeds one speed only.	Idler roll stuck.	Check for lock washer under idler roll, or replace if damaged.
	Bad potentiometer.	Check with meter.
	Broken electrical cable.	Check potentiometer wires for continuity or short.
Wire walks out of drive rolls.	Bad speed control.	See specific cabinet/control owners manual for speed control operation.
	Idler roll upside-down.	Place groove in idler roll toward top.
	Rear wire guide missing.	Replace wire guide.

Troubleshooting Guide

Regardless of which gun or feeder used, all MK Products' push-pull guns operate on the same principle. The slave motor in the feeder runs at a fast, constant speed, but has very low torque. It is always trying to feed more wire than the gun motor wants, and when the motor gets all it wants, it slows the slave motor, preventing a bird's nest. Because of the low torque produced by the slave motor, a brake system is used to prevent wire overrun rather than tension. The drag adjustment in the feeder is used simply to keep the wire slightly taut, so it will not pull off the spool while feeding wire.

The high torque 24VDC gun motor is controlled by a solid state speed control located in the feeder, and a pot located in the gun. The gun motor, potentiometer, and micro switch are connected to the cabinet/control box via a control cable and Amphenol connector. If this cable becomes damaged, a variety of symptoms can occur, depending on which wire(s) break. To test, check each wire for continuity and shorts.

Remember, the micro switch in the gun activates both the slave motor and gun motor circuits in the cabinet. Therefore, if the slave motor and brake solenoid operate, but the gun does not, look more toward the gun motor's 24V circuits, speed control, control cable, or the gun motor. If nothing operates, look more toward the slave motor's input, micro switch leads, or micro switch.

Testing The Gun

Reference the "W" clocked gun wiring diagram on the Pythor® Lincoln Compatible™ Electrical Diagram for information about pin-outs and locations.

Motor Check

Remove the gun connector from the cabinet.

Using the gun Amphenol connector, check the resistance across pins "A" and "B" (motor leads).

If an open circuit (more than **K ohms**) or short exist (less than **2 ohms**) exists, check the motor leads and motor independently.

Testing the Potentiometer - "W" Clocked

Using the gun amphenol connector, check the resistance across pin "D" (wiper) and pin "C". The resistance should vary from **0 - 5K ohms** as the potentiometer is turned.

Check the resistance across pin "D" (wiper) and pin "G". The resistance should vary from **5K - 0 ohms** as the potentiometer is turned.

Testing the Micro Switch

Using the gun Amphenol connector, check for continuity across pins "E" and "F" when the trigger is pressed.

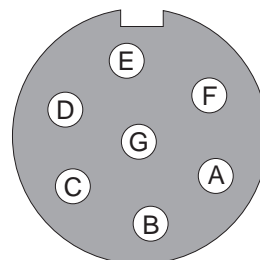

"W" Clocked

Amphenol Connector
Viewed from front of connector

THIS PAGE INTENTIONALLY BLANK

Appendices

Diagrams / Parts List

Exploded View	12
Bill of Material	13
Front Body Assembly	14
Rear Body Assembly, Air Cooled	15
Rear Body Assembly, Water Cooled.....	16
Barrel Assembly, Air Cooled	17
Barrel Assembly, Water Cooled	18
Cup Insulator and O-Ring Maintenance	19
Lead Assembly, Air Cooled.....	20
Bill of Material	21
Lead Assembly, Water Cooled.....	22
Bill of Material	23
Power Pin Adapter Assembly.....	24
Power Manifold, Air Cooled	25
Power Manifold, Water Cooled	26
Electrical	27

Python® Lincoln Compatible™ Head Assembly

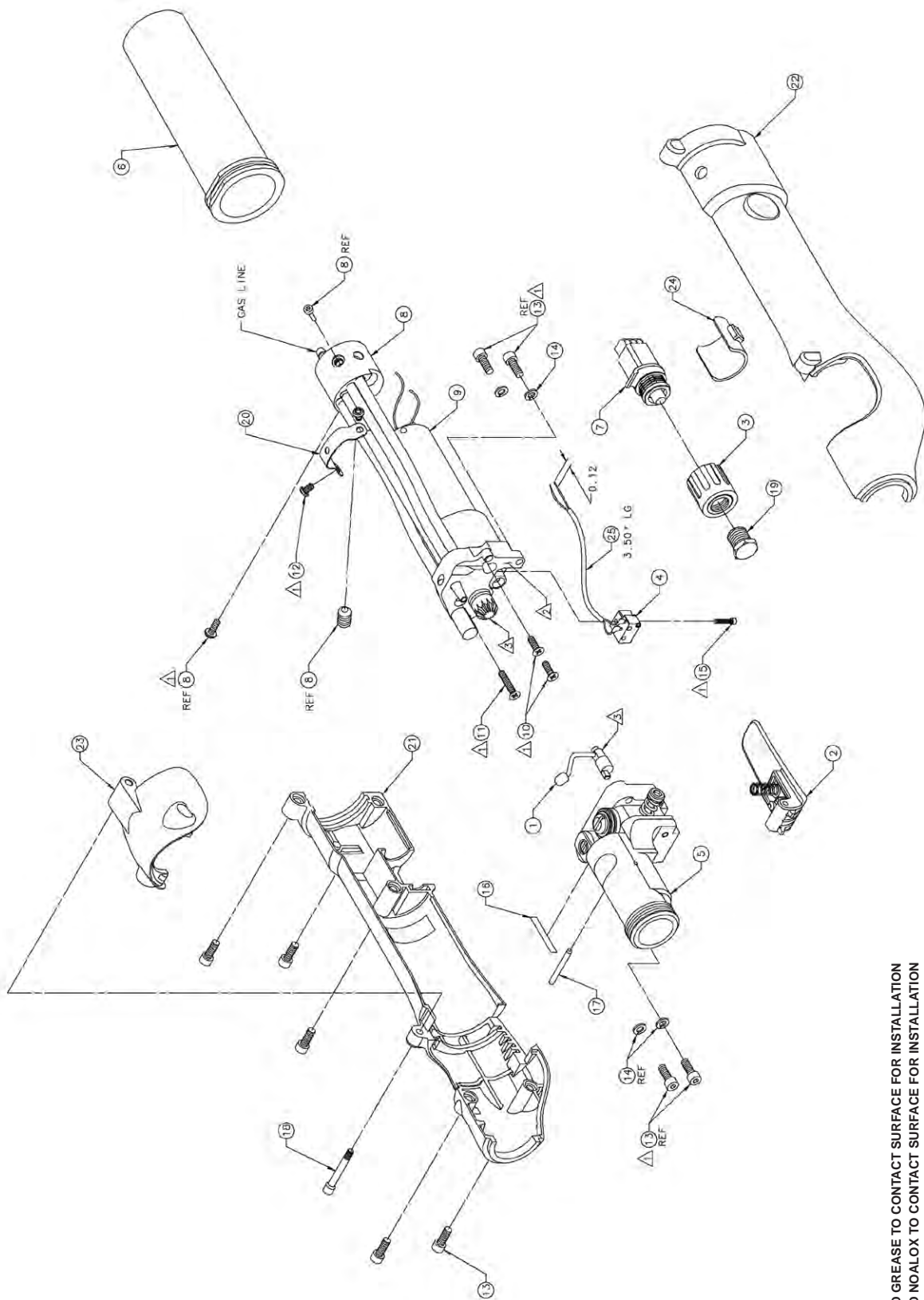

APPLY COMPOUND GREASE TO CONTACT SURFACE FOR INSTALLATION
 APPLY COMPOUND NOALOX TO CONTACT SURFACE FOR INSTALLATION
 APPLY THREAD LOCKING COMPOUND TO CONTACT SURFACE FOR INSTALLATION

Python® Lincoln Compatible™ Head Assembly

No.	Qty.	Part No.	Description	No.	Qty.	Part No.	Description
1	1	002-0629	Assy Cam Idler Arm	13	9	338-0022	Scr SHC 6-32 x 3/8 SST
2	1	005-0694	Trigger Kit	14	4	333-0260	Wshr Spr LK #6 SST
3	1	003-2125	Assy Knob Pot	15	1	338-0153	Scr SHC 1-72 x 3/8 SST
4	1	005-0701	Micro Swx Kit	16	1	405-0706	Label
5	1	003-2271	Front Body Assy, A/C	17	1	421-0018	Pin Dowel 3/32 x 7/8
6	1	003-2153	Assy Boot Torch	18	1	431-1622	Scr Shoulder 1/8 x 4-40
7	1	005-0695	Assy Speed Control Pot Kit	19	1	431-1637	Screw Hex 3/8-20 x 3/8
8	1	003-2289	Rear Body Assy, A/C	20	1	435-1585	Strap Motor Python
9	1	211-0077	Motor 24VDC, Standard	21	1	005-0699	Handle Kit: Includes line items 13,18, and 23
	1	211-0080	Motor 24VDC, Hi-Speed (optional)	22			
10	2	319-0254	Scr FH Phil 82 4-40 x 3/8 SST	23	1	437-0253	Door Molded Python
11	1	319-0258	Scr FH Phil 82 4-40 5/8 SST	24	1	437-0268	Cover Knob Python
12	2	320-0101	Scr Button 4-40 x 3/16 SST	25	0.30 ft.	737-0048	Tube, Insulation 9 AWG, Clear

Python® Lincoln Compatible™
Front Body Assembly
P/N 003-2271 (Air Cooled)
P/N 003-2108 (Water Cooled)

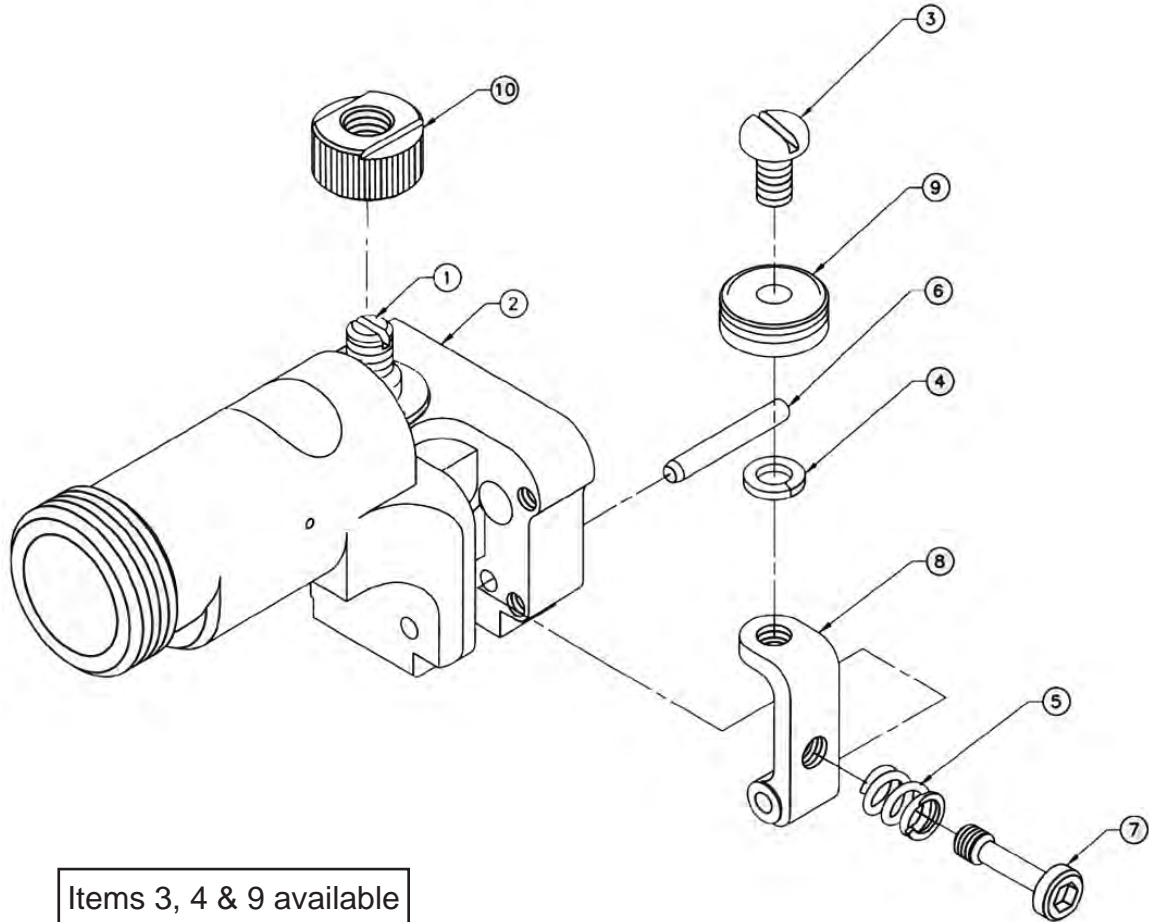

Items 3, 4 & 9 available
as package kit:
P/N 005-0686

Front Body Assembly			
No.	Qty.	Part No.	Description
1	-	-	Not available separately
2	-	-	
3*	1	325-0206	10-24 x 3/8 PH Screw
4*	1	333-0082	# 10 Lock Washer
5	1	419-0092	0.29 x 0.047 x 0.32 Comp. Spring
6	1	421-0525	1/8 x 7/8 SST Dowel Pin
7	1	431-1663	Idler Adjusting Screw
8	1	431-1598	Idler Arm
9*	1	511-0001	Idler Wire Feed Assembly
10	1	511-0101	Drive roll

* Items 3, 4 & 9 available as package kit: **Part number 005-0686**

Python® Lincoln Compatible™ Rear Body Assembly, Air Cooled P/N 003-2289

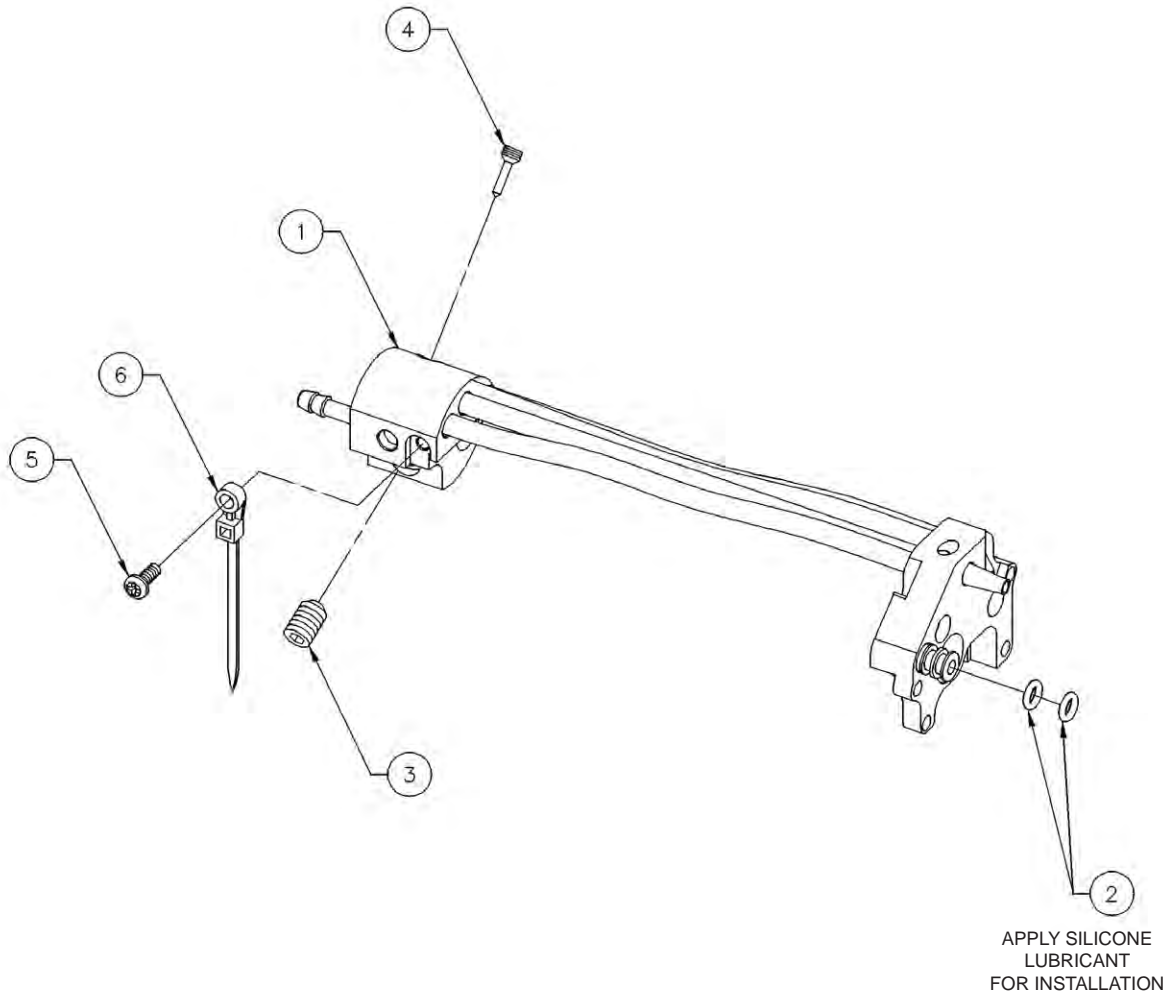

Air Cooled Rear Body Assembly			
No.	Qty.	Part No.	Description
1	-	-	Not available separately
2	2	303-0096	O-Ring .145 ID x .07 W
3	1	321-1082	Set Screw Flat 1/4-20 5/16 SST
4	1	321-1104	Set Screw Mod Conduit
5	1	336-0020	Scr PH Phil 4-40 x 5/16 SST
6	1	411-0243	Tie Wrap Scr 4

Python® Lincoln Compatible™ Rear Assembly, Water Cooled P/N 003-2287

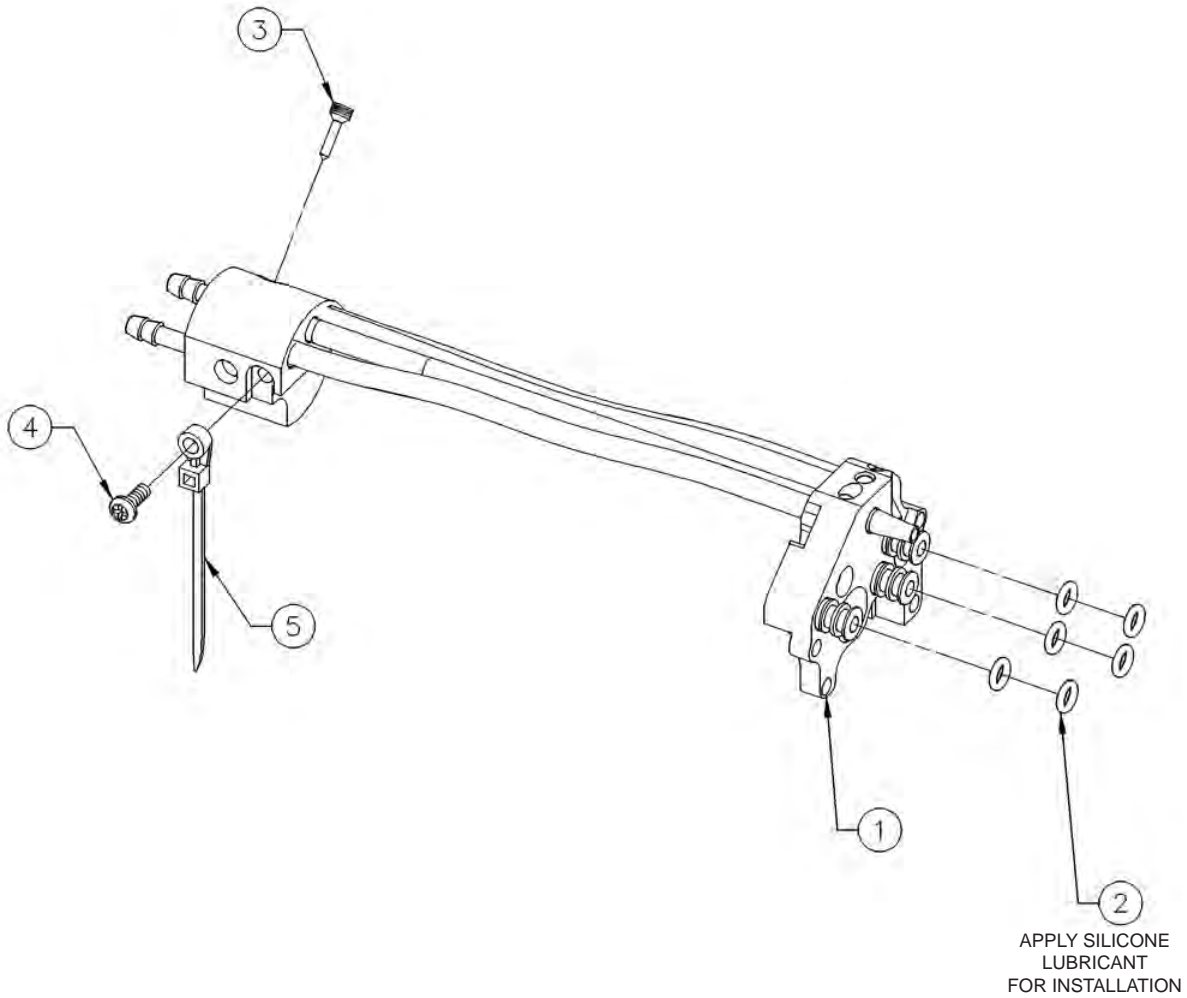

Water Cooled Rear Body Assembly			
No.	Qty.	Part No.	Description
1	-	-	Not available separately
2	6	303-0096	O-Ring .145 ID x .07 W
3	1	321-1104	Set Screw Mod Conduit
4	1	336-0020	Scr PH Phil 4-40 x 5/16 SST
5	1	411-0243	Tie Wrap Scr 4

Python® Lincoln Compatible™ Barrel Assembly, Air Cooled P/N 003-2272

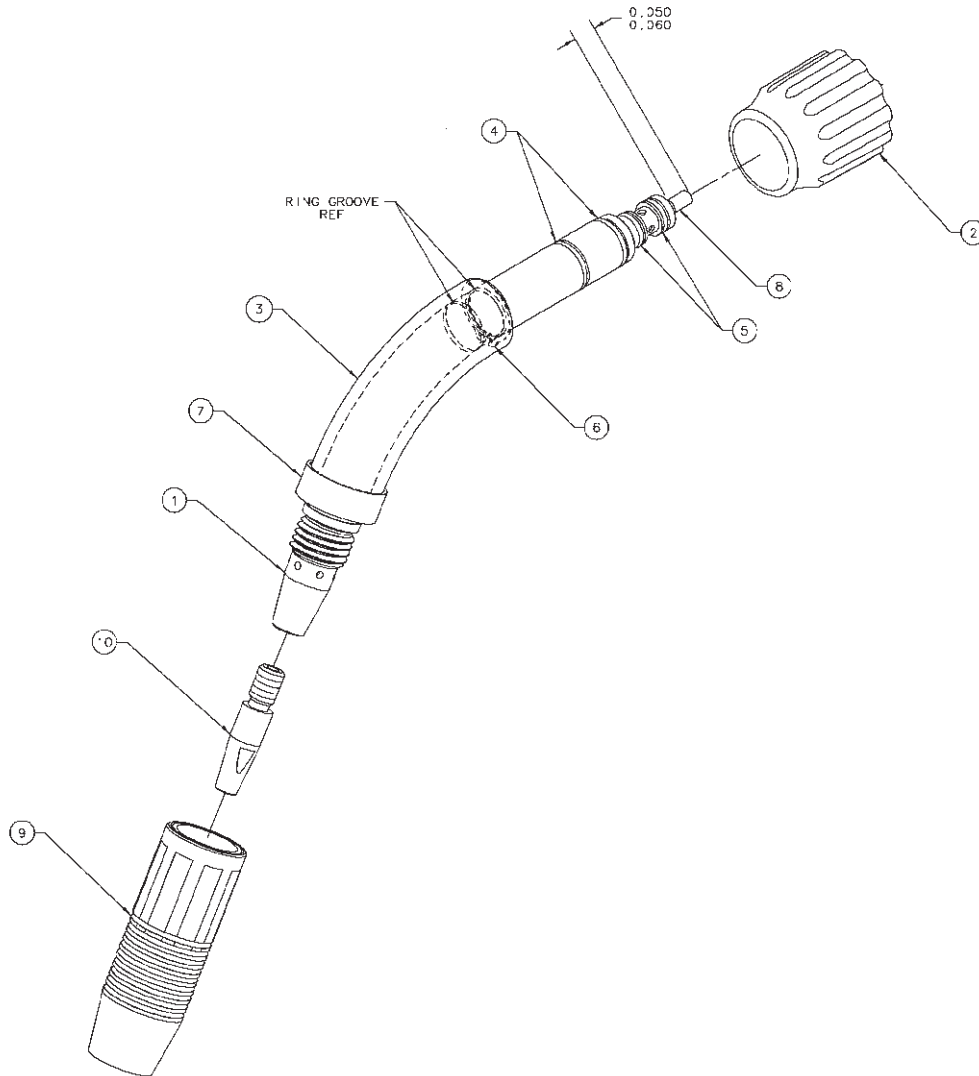

*Apply silicone lubricant to items 4 and 5 before installing.

No.	Qty.	Part Number	Description
1	-	-	Not available separately
2	1	005-0696	Taper Lock Kit
3	1	261-0143	Insulator Barrel
4*	2	303-0010	O-Ring .489 ID x .07 W
5*	2	303-0094	O-Ring .301 ID x .07 W
6	1	313-0091	Retaining Ring 5/8 Shaft
7	1	431-1774	Cup Insulator Barrel
8	0.63 ft	615-0178	Liner Tef 0.084 ID x 0.174 OD
9	1	621-0250	Assy Cup Copper Finned #10
10	1	621-0393	Tip HD Spray .060

Python® Lincoln Compatible™ Barrel Assembly, Water Cooled P/N 003-2317

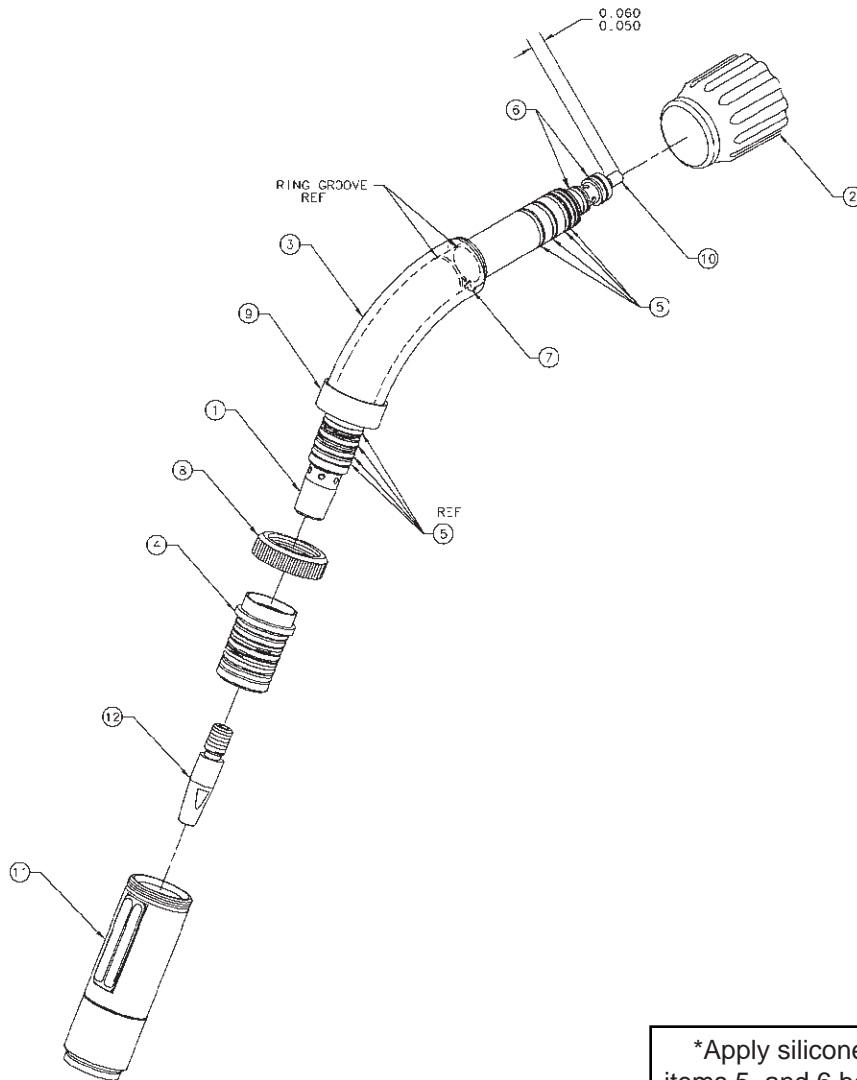

*Apply silicone lubricant to items 5, and 6 before installing.

Water Cooled 60° Curved Barrel Assembly			
No.	Qty.	Part No.	Description
1	-	-	Not available separately
2	1	005-0696	Taper Lock Kit
3	1	261-0141	Insulator Barrel
4	1	261-0381	Insulator Cup with five O-Rings
5*	8	303-0010	O-Ring .489 ID x .07 W
6*	2	303-0094	O-Ring .301 ID x .07 W
7	1	313-0091	Retaining Ring 5/8 Shaft
8	1	431-0977	Retaining Nut
9	1	431-1774	Cup Insulator Barrel
10	0.70 ft.	615-0178	Liner Tef 0.084 ID x 0.174 OD
11	1	621-0065	Cup #10 Assy
12	1	621-0393	Tip HD Spray .060

CUP INSULATOR AND O-RING MAINTENANCE

CAUTION: Power-off the coolant pump before disassembling water-cooled barrels.

1. Unscrew Retaining Nut and slide back on barrel.
2. Using a firm pull and twist action, the Water-Cooled Gas Cup or Air-Cooled Gas Cup Assembly can be removed from the Cup Insulator.
3. Inspect the Cup Insulator and o-rings (included with Insulator) for wear and proper lubrication. It is considered good practice to replace all o-rings at the same time.
4. To remove the Cup Insulator, it must be unscrewed and pulled from the barrel. Use a rag or towel (due to o-ring lubrication) and wrap it around the Cup Insulator.

Unscrew and pull when completed unthreaded from barrel. Be sure the Insulator is fully unscrewed from the threads. Pulling the Insulator over barrel threads will damage the threads on the Insulator.

Inspect o-rings on barrel for wear and lubrication. It is considered good practice to replace all o-rings at the same time.

5. To install the Cup Insulator, it must be pushed all the way onto the barrel then screwed onto the threads. If necessary, place small amount of o-ring lubricant on the inside diameter of the Cup Insulator, this will help it slide onto the barrel.

Push the Insulator onto the barrel until it bottoms out, screw onto barrel threads.

The Insulator **MUST** be all the way onto the barrel to avoid assure proper coolant passage and from blocking the gas outlet orifices.

6. Push Water-Cooled Gas Cup or Chrome Nut, Cup Adapter and Gas Cup Assembly onto Cup Insulator. Slide Retaining Nut forward and tighten.

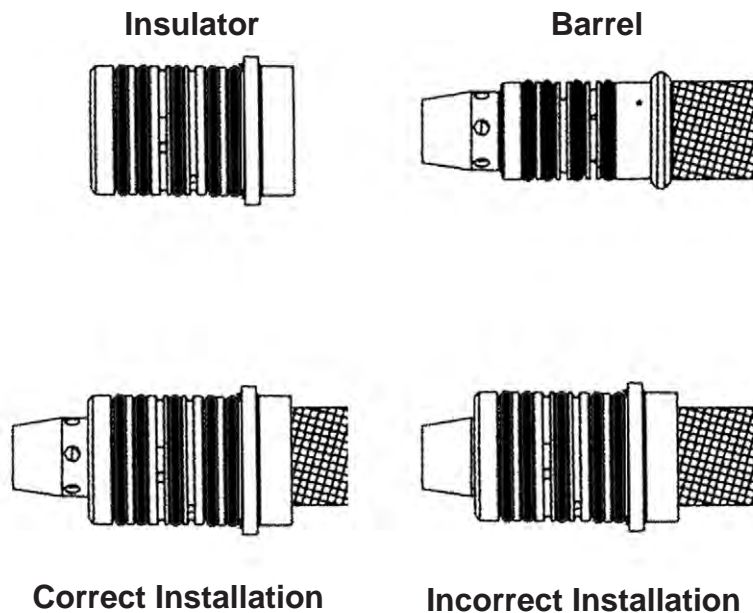

Python® Lincoln Compatible™ Lead Assembly Air Cooled

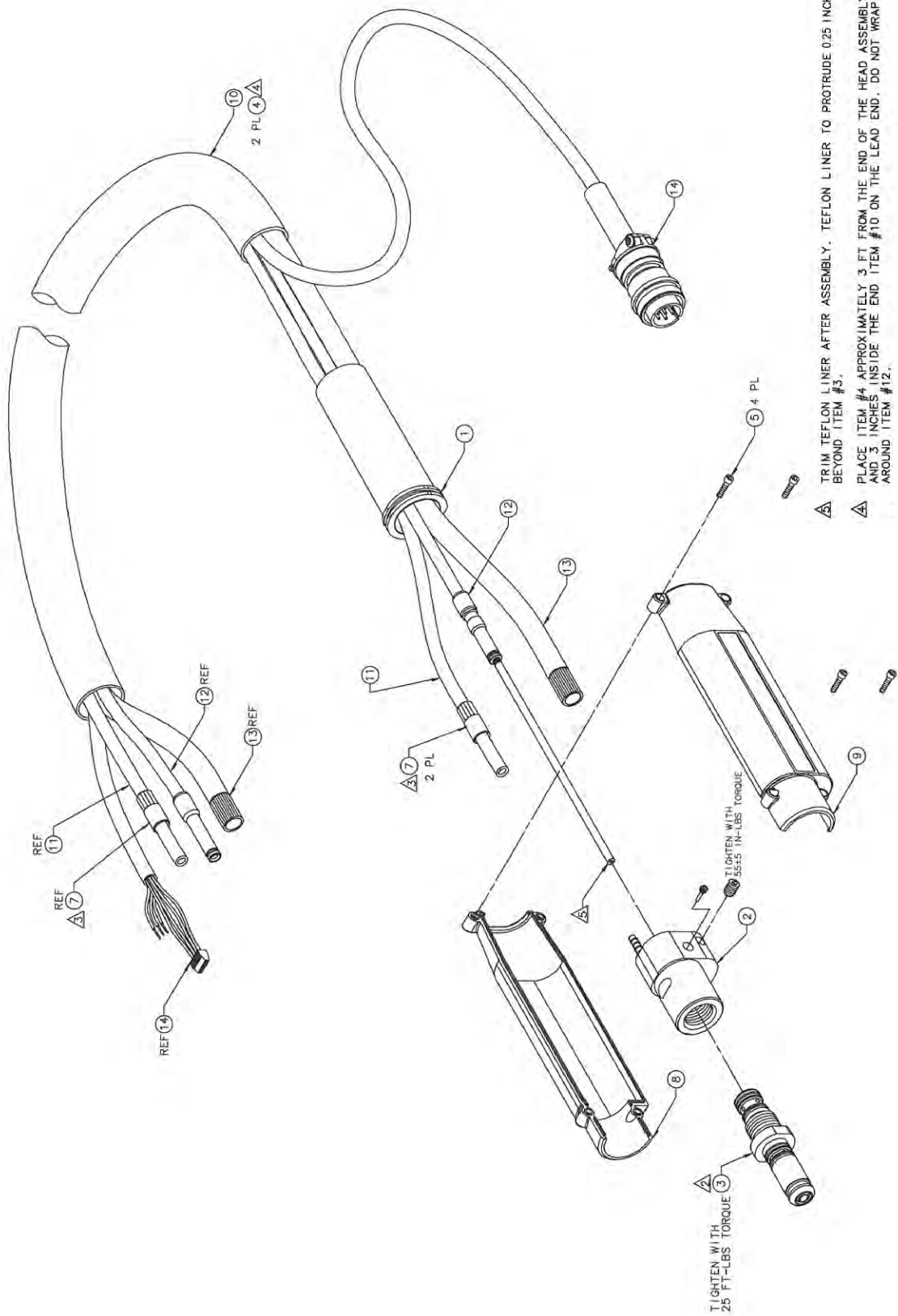

- ⚠ TRIM TEFLON LINER AFTER ASSEMBLY. TEFLON LINER TO PROTRUDE 0.25 INCHES BEYOND ITEM #5.
- ⚠ PLACE ITEM #4 APPROXIMATELY 3 FT FROM THE END OF THE HEAD ASSEMBLY AND 3 INCHES INSIDE THE END ITEM #10 ON THE LEAD END. DO NOT WRAP AROUND ITEM #12.
- ⚠ APPLY QUICK DRYING HOSE LUBRICANT NEAR END OF ITEM #11 FOR INSTALLATION OF ITEM #7.
- ⚠ APPLY COMPOUND JOINT NOALOX TO THE CONTACT SURFACE BETWEEN ITEM #2 AND ITEM #3.
- ⚠ ITEM NOT SHOWN FOR CLARITY.

Lead Assembly - Air Cooled						
No.	Qty.	Description	15' Part No.	25' Part No.	35' Part No.	50' Part No.
1	1	Assy Boot Torch		003-2153		
2	1	Assy Power Manifold, A/C		003-2337		
3	1	Assy Power Pin Adapter		003-2346		
4	△ 2	Wrap Spiral Cord		261-0094		
5	4	Screw SHC 4-40 x 1/2 SST		338-0014		
6	△ 4	Tie Wrap .75 x Dia N Blk		411-0045		
7*	2	Hose Retainer, 5/16		431-1898		
8	1	Handle RH Lead Universal		437-0315-RED		
9	1	Handle LH Lead Universal		437-0316-RED		
10	1	Snake Skin	931-0110	931-0122	931-0132	931-0123
11	1	Assy Gas Hose	552-0241-15	552-0241-25	552-0241-35	552-0241-50
12	1	Conduit Tef Tube	615-0620-15	615-0620-25	615-0620-35	615-0620-50
13	1	Assy Power Cable Global	843-0640-15	843-0640-25	843-0640-35	843-0640-50
14	1	Assy Controller Cable	005-0690	005-0691	005-0740	005-0692

* Hose Retainer is re-usable and can be removed and re-installed as needed

Lead Assembly - Water Cooled					
No. Qty.	Description	15' Part No.	25' Part No.	35' Part No.	50' Part No.
1	Assy Boot Torch		003-2153		
2	Assy Power Manifold, W/C		003-2345		
3	Assy Power Pin Adapter		003-2346		
4	△ 2 Wrap Spiral Cord		261-0094		
5	4 Screw SHC 4-40 x 1/2 SST		338-0014		
6	△ 4 Tie Wrap .75 x Dia N Blk		411-0045		
7*	4 Hose Retainer, 5/16		431-1898		
8	1 Handle RH Lead Universal		437-0315-RED		
9	1 Handle LH Lead Universal		437-0316-RED		
10	1 Assy Hose Water RED		552-0209		
11	1 Snake Skin	931-0110	931-0122	931-0132	931-0123
12	1 Assy Gas Hose	552-0241-15	552-0241-25	552-0241-35	552-0241-50
13	1 Assy Hose Water, BLUE	552-0239-15	552-0239-25	552-0239-35	552-0239-50
14	1 Conduit Tef Tube	615-0620-15	615-0620-25	615-0620-35	615-0620-50
15	1 Assy Controller Cable	005-0690	005-0691	005-0740	005-0692
16	1 Assy Power Cable/Water Euro	843-0680-15	843-0680-25	843-0680-35	843-0680-50

* Hose Retainer is re-usable and can be removed and re-installed as needed

Python® Lincoln Compatible™ Power Pin Adapter Assembly P/N 003-2346

APPLY SILICONE LUBRICANT TO
O-RINGS BEFORE INSTALLING

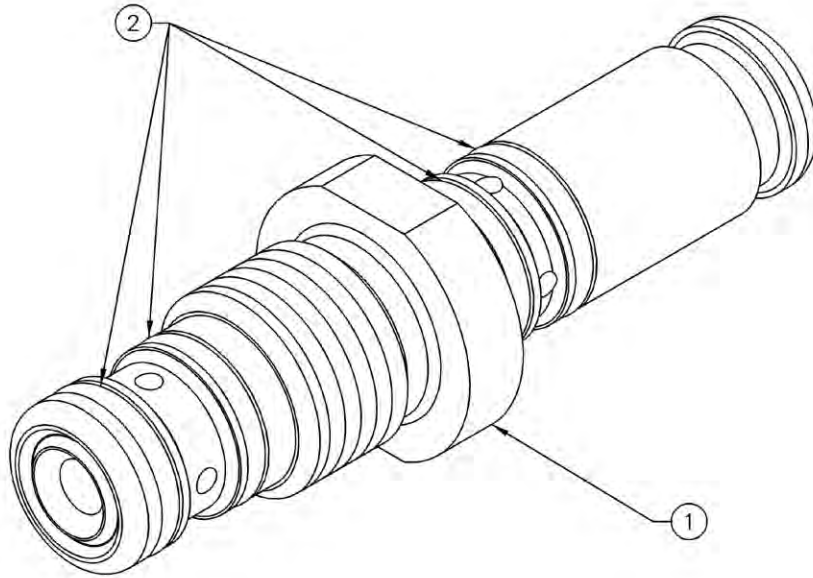

Power Pin Adapter Assembly			
No.	Qty.	Part No.	Description
1	1	002-0761	Assy Brazed Power Pin Adapter
2	4	303-0010	O-Ring 2-014 .489 ID x .07 W

Python® Lincoln Compatible™ Power Manifold Assembly, Air Cooled P/N 003-2337

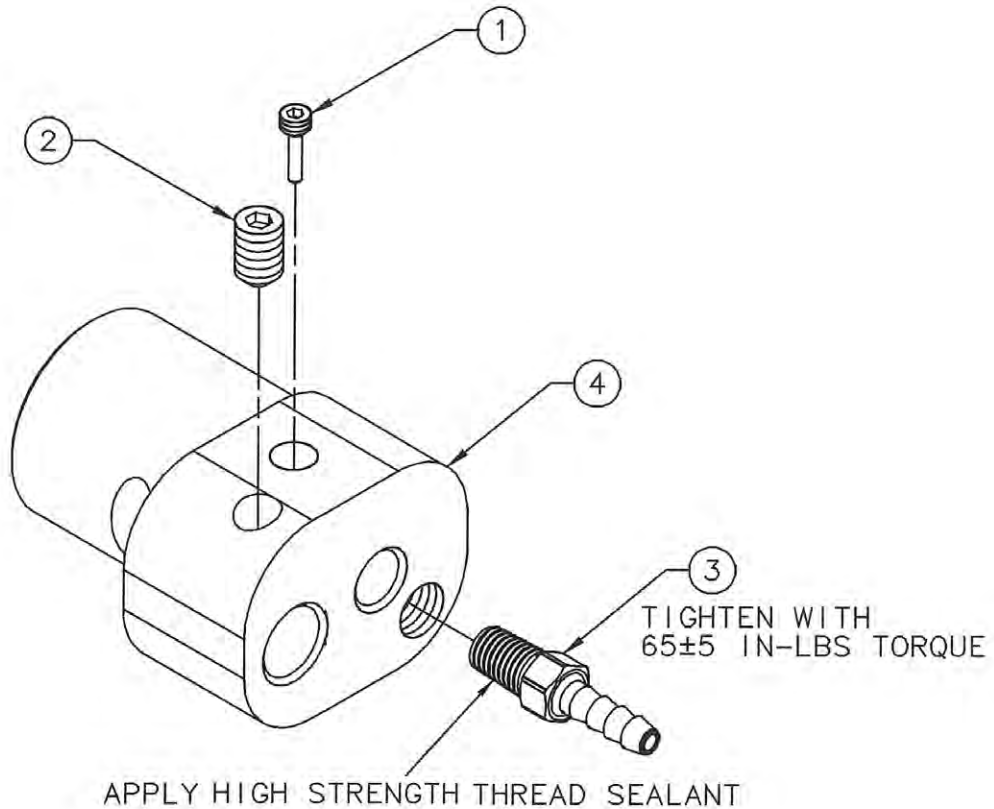

Air Cooled Power Manifold Assembly			
No.	Qty.	Part No.	Description
1	1	321-1104	Set Screw Conduit
2	1	321-1082	Set Screw Flat 1/4 - 20 x 3/8 SST
3	1	431-1905	Fitting 1/8 ID x 1/16 - 27 NPT
3	1	431-1936	Power Manifold AC

Python® Lincoln Compatible™ Power Manifold Assembly, Water Cooled P/N 003-2345

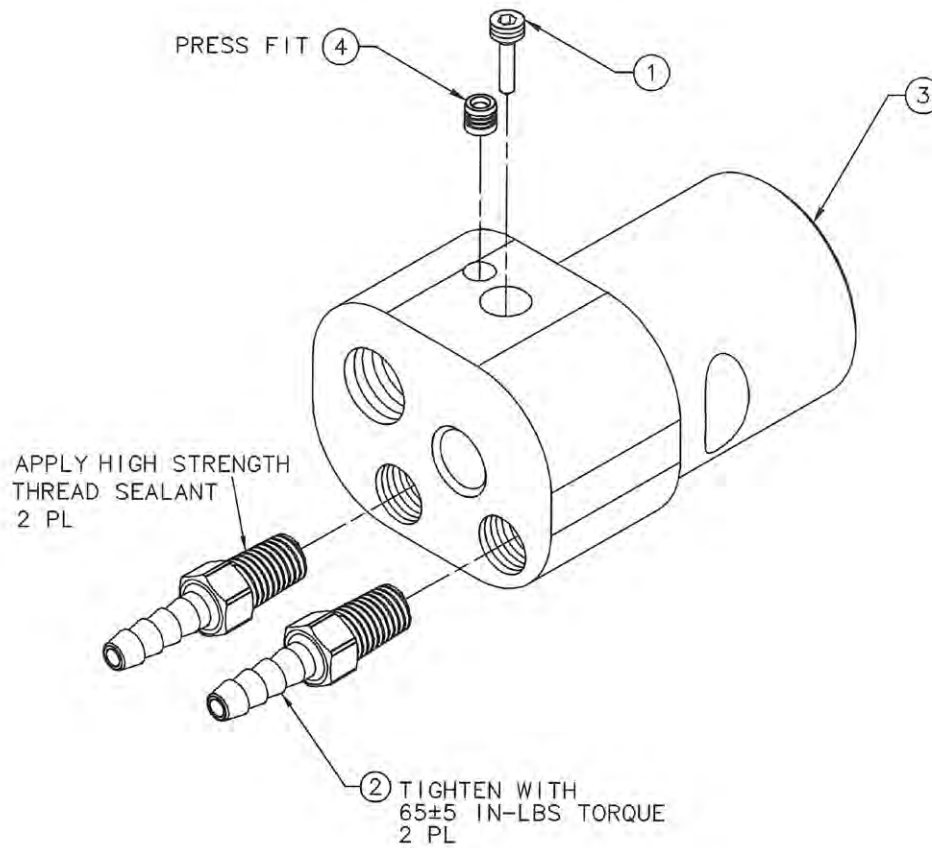

Water Cooled Power Manifold Assembly			
No.	Qty.	Part No.	Description
1	1	321-1104	Set Screw Conduit
2	2	431-1905	Fitting 1/8 ID x 1/16 - 27 NPT
3	1	431-1951	Power Manifold WC
4	1	751-0017	Plug Sealing 4MM x 4MM SST

Python® Lincoln Compatible™ Electrical

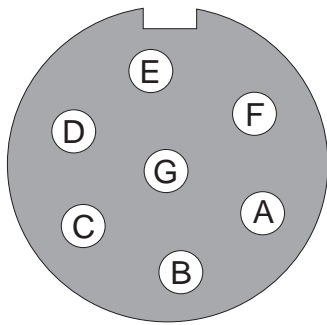

"W" Clocked
Amphenol Connector
Viewed from front of connector

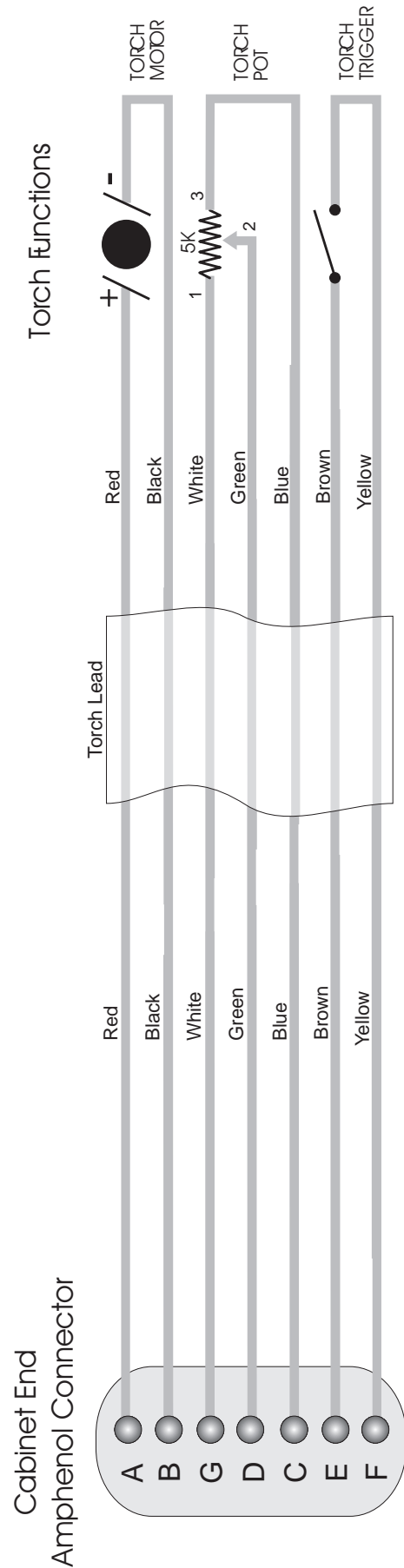

			
WARNING	<ul style="list-style-type: none"> Do not touch electrically live parts or electrode with skin or wet clothing. Insulate yourself from work and ground. 	<ul style="list-style-type: none"> Keep flammable materials away. 	<ul style="list-style-type: none"> Wear eye, ear and body protection.
Spanish AVISO DE PRECAUCION	<ul style="list-style-type: none"> No toque las partes o los electrodos bajo carga con la piel o ropa mojada. Aislese del trabajo y de la tierra. 	<ul style="list-style-type: none"> Mantenga el material combustible fuera del área de trabajo. 	<ul style="list-style-type: none"> Protéjase los ojos, los oídos y el cuerpo.
French ATTENTION	<ul style="list-style-type: none"> Ne laissez ni la peau ni des vêtements mouillés entrer en contact avec des pièces sous tension. Isolez-vous du travail et de la terre. 	<ul style="list-style-type: none"> Gardez à l'écart de tout matériel inflammable. 	<ul style="list-style-type: none"> Protégez vos yeux, vos oreilles et votre corps.
German WARNUNG	<ul style="list-style-type: none"> Berühren Sie keine stromführenden Teile oder Elektroden mit Ihrem Körper oder feuchter Kleidung! Isolieren Sie sich von den Elektroden und dem Erdboden! 	<ul style="list-style-type: none"> Entfernen Sie brennbares Material! 	<ul style="list-style-type: none"> Tragen Sie Augen-, Ohren- und Körperschutz!
Portuguese ATENÇÃO	<ul style="list-style-type: none"> Não toque partes elétricas e electrodos com a pele ou roupa molhada. Isole-se da peça e terra. 	<ul style="list-style-type: none"> Mantenha inflamáveis bem guardados. 	<ul style="list-style-type: none"> Use proteção para a vista, ouvido e corpo.
Japanese 注意事項	<ul style="list-style-type: none"> ● 通電中の電気部品、又は溶材にヒフやぬれた布で触れないこと。 ● 施工物やアースから身体が絶縁されている様にして下さい。 	<ul style="list-style-type: none"> ● 燃えやすいものの側での溶接作業は絶対にしてはなりません。 	<ul style="list-style-type: none"> ● 目、耳及び身体に保護具をして下さい。
Chinese 警告	<ul style="list-style-type: none"> ● 皮肤或湿衣物切勿接触带电部件及焊条。 ● 使你自已与地面和工件绝缘。 	<ul style="list-style-type: none"> ● 把一切易燃物品移离工作场所。 	<ul style="list-style-type: none"> ● 佩戴眼、耳及身体劳动保护用具。
Korean 위험	<ul style="list-style-type: none"> ● 전도체나 용접봉을 젖은 헝겊 또는 피부로 절대 접촉치 마십시오. ● 모재와 접지를 접촉치 마십시오. 	<ul style="list-style-type: none"> ● 인화성 물질을 접근시키지 마십시오. 	<ul style="list-style-type: none"> ● 눈, 귀와 몸에 보호장구를 착용하십시오.
Arabic تحذير	<ul style="list-style-type: none"> ● لا تلمس الأجزاء التي يسري فيها التيار الكهربائي أو الأقطاب بجلد الجسم أو بالملايس المبللة بالماء. ● ضع عازلا على جسمك خلال العمل. 	<ul style="list-style-type: none"> ● ضع المواد القابلة للاشتعال في مكان بعيد. 	<ul style="list-style-type: none"> ● ضع أدوات وملابس واقية على عينيك وأذنيك وجسمك.

READ AND UNDERSTAND THE MANUFACTURER'S INSTRUCTION FOR THIS EQUIPMENT AND THE CONSUMABLES TO BE USED AND FOLLOW YOUR EMPLOYER'S SAFETY PRACTICES.

SE RECOMIENDA LEER Y ENTENDER LAS INSTRUCCIONES DEL FABRICANTE PARA EL USO DE ESTE EQUIPO Y LOS CONSUMIBLES QUE VA A UTILIZAR, SIGA LAS MEDIDAS DE SEGURIDAD DE SU SUPERVISOR.

LISEZ ET COMPRENEZ LES INSTRUCTIONS DU FABRICANT EN CE QUI REGARDE CET EQUIPMENT ET LES PRODUITS A ETRE EMPLOYES ET SUIVEZ LES PROCEDURES DE SECURITE DE VOTRE EMPLOYEUR.

LESEN SIE UND BEFOLGEN SIE DIE BETRIEBSANLEITUNG DER ANLAGE UND DEN ELEKTRODENEINSATZ DES HERSTELLERS. DIE UNFALLVERHÜTUNGSVORSCHRIFTEN DES ARBEITGEBERS SIND EBENFALLS ZU BEACHTEN.

			
<ul style="list-style-type: none"> • Keep your head out of fumes. • Use ventilation or exhaust to remove fumes from breathing zone. 	<ul style="list-style-type: none"> • Turn power off before servicing. 	<ul style="list-style-type: none"> • Do not operate with panel open or guards off. 	WARNING
<ul style="list-style-type: none"> • Los humos fuera de la zona de respiración. • Mantenga la cabeza fuera de los humos. Utilice ventilación o aspiración para gases. 	<ul style="list-style-type: none"> • Desconectar el cable de alimentación de poder de la máquina antes de iniciar cualquier servicio. 	<ul style="list-style-type: none"> • No operar con panel abierto o guardas quitadas. 	Spanish AVISO DE PRECAUCION
<ul style="list-style-type: none"> • Gardez la tête à l'écart des fumées. • Utilisez un ventilateur ou un aspirateur pour ôter les fumées des zones de travail. 	<ul style="list-style-type: none"> • Débranchez le courant avant l'entretien. 	<ul style="list-style-type: none"> • N'opérez pas avec les panneaux ouverts ou avec les dispositifs de protection enlevés. 	French ATTENTION
<ul style="list-style-type: none"> • Vermeiden Sie das Einatmen von Schweißrauch! • Sorgen Sie für gute Be- und Entlüftung des Arbeitsplatzes! 	<ul style="list-style-type: none"> • Strom vor Wartungsarbeiten abschalten! (Netzstrom völlig öffnen; Maschine anhalten!) 	<ul style="list-style-type: none"> • Anlage nie ohne Schutzgehäuse oder Innenschutzverkleidung in Betrieb setzen! 	German WARNUNG
<ul style="list-style-type: none"> • Mantenha seu rosto da fumaça. • Use ventilação e exaustão para remover fumo da zona respiratória. 	<ul style="list-style-type: none"> • Não opere com as tampas removidas. • Desligue a corrente antes de fazer serviço. • Não toque as partes elétricas nuas. 	<ul style="list-style-type: none"> • Mantenha-se afastado das partes moventes. • Não opere com os painéis abertos ou guardas removidas. 	Portuguese ATENÇÃO
<ul style="list-style-type: none"> ● ヒュームから頭を離すようにして下さい。 ● 換気や排煙に十分留意して下さい。 	<ul style="list-style-type: none"> ● メンテナンス・サービスに取りかかる際には、まず電源スイッチを必ず切して下さい。 	<ul style="list-style-type: none"> ● パネルやカバーを取り外したまま機械操作をしないで下さい。 	Japanese 注意事項
<ul style="list-style-type: none"> ● 頭部遠離煙霧。 ● 在呼吸區使用通風或排風器除煙。 	<ul style="list-style-type: none"> ● 維修前切斷電源。 	<ul style="list-style-type: none"> ● 僅表板打開或沒有安全罩時不準作業。 	Chinese 警告
<ul style="list-style-type: none"> ● 얼굴로부터 용접가스를 멀리하십시오. ● 호흡지역으로부터 용접가스를 제거하기 위해 가스제거기나 통풍기를 사용하십시오. 	<ul style="list-style-type: none"> ● 보수전에 전원을 차단하십시오. 	<ul style="list-style-type: none"> ● 패널이 열린 상태로 작동치 마십시오. 	Korean 위험
<ul style="list-style-type: none"> ● ابعء رأسك بعيداً عن الدخان. ● استعمل التهوية أو جهاز ضغط الدخان للخارج لكي تبعد الدخان عن المنطقة التي تنفس فيها. 	<ul style="list-style-type: none"> ● قطع التيار الكهربائي قبل القيام بأية صيانة. 	<ul style="list-style-type: none"> ● لا تشغيل هذا الجهاز إذا كانت الاغطية الحديدية الواقية ليست عليه. 	Arabic تحذير

LEIA E COMPREENDA AS INSTRUÇÕES DO FABRICANTE PARA ESTE EQUIPAMENTO E AS PARTES DE USO, E SIGA AS PRÁTICAS DE SEGURANÇA DO EMPREGADOR.

使う機械や溶材のメーカーの指示書をよく読み、まず理解して下さい。そして貴社の安全規定に従って下さい。

請詳細閱讀並理解製造廠提供的說明以及應該使用的銀焊材料，並請遵守貴方的有關勞動保護規定。

이 제품에 동봉된 작업지침서를 숙지하시고 귀사의 작업자 안전수칙을 준수하시기 바랍니다.

اقرأ بتمعن وافهم تعليمات المصنع المنتج لهذه المعدات والمواد قبل استعمالها واتبع تعليمات الوقاية لصاحب العمل.

LIMITED WARRANTY

Effective August 1, 2010

This warranty supersedes all previous MK Products warranties and is exclusive, with no other guarantees or warranties expressed or implied.

LIMITED WARRANTY - MK Products Inc., Irvine, California warrants that all new and unused equipment furnished by MK Products is free from defects in workmanship and material as of the time and place of delivery by MK Products. No warranty is made by MK Products with respect to trade accessories or other items manufactured by others. Such trade accessories and other items are sold subject to the warranties of their respective manufacturers, if any.

MK Products' warranty does not apply to components having normal useful life of less than one (1) year, such as relay points, wire conduit, tungsten, and welding gun parts that come in contact with the welding wire, including gas cups, gas cup insulators, and contact tips where failure does not result from defect in workmanship or material.

MK Products shall, exclusively remedy the limited warranty or any duties with respect to the quality of goods, based upon the following options:

- (1) repair
- (2) replacement
- (3) where authorized in writing by MK Products, the reasonable cost of repair or replacement at our Irvine, California plant.

As a matter of general policy only, MK Products may honor an original user's warranty claims on warranted equipment in the event of failure resulting from a defect within the following periods from the date of delivery of equipment to the original user:

1. **Power Supplies and Wire Feed Cabinets** 3 years
2. **Weldheads, Coolers, Positioners, and Push-Pull Guns** ... 1 year
3. **Spool Guns, and Spool Gun Modules** 180 days
4. **Repairs/Exchanges/Parts** 90 days

Classification of any item into the foregoing categories shall be at the sole discretion of MK Products. Notification of any failure must be made in writing within 30 days of such failure.

A copy of the invoice showing the date of sale must accompany products returned for warranty repair or replacement.

All equipment returned to MK Products for service must be properly packaged to guard against damage from shipping. MK Products will not be responsible for any damages resulting from shipping.

Normal surface transportation charges (one way) for products returned for warranty repair or replacement will be borne by MK Products, except for products sold to foreign markets.

ANY EXPRESS WARRANTY NOT PROVIDED HEREIN AND ANY IMPLIED WARRANTY, GUARANTY, OR REPRESENTATION AS TO PERFORMANCE, AND ANY REMEDY FOR BREACH OF CONTRACT WHICH, BUT FOR THIS PROVISION, MIGHT ARISE BY IMPLICATION, OPERATION OF LAW, CUSTOM OF TRADE, OR COURSE OF DEALING, INCLUDING ANY IMPLIED WARRANTY OF MERCHANTABILITY OR OF FITNESS FOR PARTICULAR PURPOSE, WITH RESPECT TO ANY AND ALL EQUIPMENT FURNISHED BY MK PRODUCTS, IS EXCLUDED AND DISCLAIMED BY MK PRODUCTS.

EXCEPT AS EXPRESSLY PROVIDED BY MK PRODUCTS IN WRITING, MK'S PRODUCTS ARE INTENDED FOR ULTIMATE PURCHASE BY COMMERCIAL/INDUSTRIAL USERS AND FOR OPERATION BY PERSONS TRAINED AND EXPERIENCED IN THE USE AND MAINTENANCE OF WELDING EQUIPMENT AND NOT FOR CONSUMERS OR CONSUMER USE. MK PRODUCTS' WARRANTIES DO NOT EXTEND TO, AND NO RE-SELLER IS AUTHORIZED TO EXTEND MK PRODUCTS' WARRANTIES TO ANY CONSUMER.

USE OF OTHER THAN **GENUINE** MK PRODUCTS' CONSUMABLES, PARTS, AND ACCESSORIES MAY INVALIDATE YOUR PRODUCT WARRANTY.



16882 Armstrong Ave.
Irvine, CA 92606
Tel (949)863-1234 Fax (949)474-1428
www.mkproducts.com

August 1, 2010

THIS PAGE INTENTIONALLY BLANK



16882 Armstrong Ave.

Irvine, CA 92606

Tel (949)863-1234 • Fax (949)474-1428

www.mkproducts.com